

Totally Logical

## Z86129/130/131 NTSC LINE 21 DECODER

### FEATURES

Devices	Speed (MHz)	Pin Count/ Package Types	Standard Temp. Range	On-Screen Display & Closed Captioning	Automatic Data Extraction	
					V-Chip	Time of Day
Z86129	12	18-Pin DIP, SOIC	0° to +70°C	Yes	Yes	Yes
Z86130	12	18-Pin DIP, SOIC	0° to +70°C	No	Yes*	Yes*
Z86131	12	18-Pin DIP, SOIC	0° to +70°C	No	No	Yes

**Note:** \*The Z86130 recovers the line 21 data in both of field1 and field2. It also has V-Chip-specific registers and the output (pin-13) to control program blocking with minimal communications between the Z86130 and the host processor.

- Complete Stand-Alone Line 21 Decoder for Closed-Captions and Extended Data Services (XDS).
- Preprogrammed to Provide Full Compliance with EIA-608 Specifications for Extended Data Services.
- Automatic Extraction and Serial Output of Special XDS Packets such as Time of Day, Local Time Zone, and Program Blocking (*V-Chip*).
- Cost-Effective Solution for NTSC Violence Blocking inside Picture-in-Picture (PiP) Windows.
- Minimal Communications and Control Overhead Provides Simple Implementation of Violence Blocking, Closed Captioning, and Auto Clock Set Features.
- Programmable, Full Screen On-Screen Display (OSD) for Creating OSD or Captions inside a Picture-in-Picture (PiP) Window (Z86129 only).
- I<sup>2</sup>C Serial Data and Control Communication
- User-Programmable Horizontal Display Position for easy OSD Centering and Adjustment (Z86129 only).

### GENERAL DESCRIPTION

The Z86129/130/131 is a stand-alone integrated circuit, capable of processing Vertical Blanking Interval (VBI) data from both fields of the video frame in data conforming to the transmission format defined in the Television Decoder Circuits Act of 1990 and in accordance with the Electronics Industry Association specification 608 (EIA-608).

The Line 21 data stream can consist of data from several data channels multiplexed together. Field 1 has four data channels: two Captions and two Text. Field 2 has five additional data channels: two Captions, two Text and Extended Data Services (XDS). XDS data structure is defined in EIA-608. The Z86129 can recover and display data transmitted on any of these nine data channels. The Z86130 and Z86131 are derivatives of the Z86129. The Z86130 and Z86131 do not have OSD capability, but are ideally suited for Line 21 data slicer applications.

The Z86129/130/131 can recover and output to a host processor via the I<sup>2</sup>C serial bus the recovered XDS data packet defined in EIA-608 as it is defined in the table above (Z86130 provides the raw Line 21 data, which must be decoded properly for the applications). On-chip XDS filters in Z86129 is fully programmable, enabling recovery of only those XDS data packets selected by the user. The Z86131 is designed especially for extracting XDS time information with proper XDS filter setup for Automatic Clock-Set features in TVs, VCRs, and Set-Top boxes. And the Z86130 is designed especially for V-Chip and Line 21 data recovery.

In addition, the Z86129/130 is ideally suited to monitor Line 21 of video displayed in a PiP window for violence blocking purposes. A block diagram of the Z86129/130/131 is illustrated in Figures 1 and 2.

GENERAL DESCRIPTION (Continued)

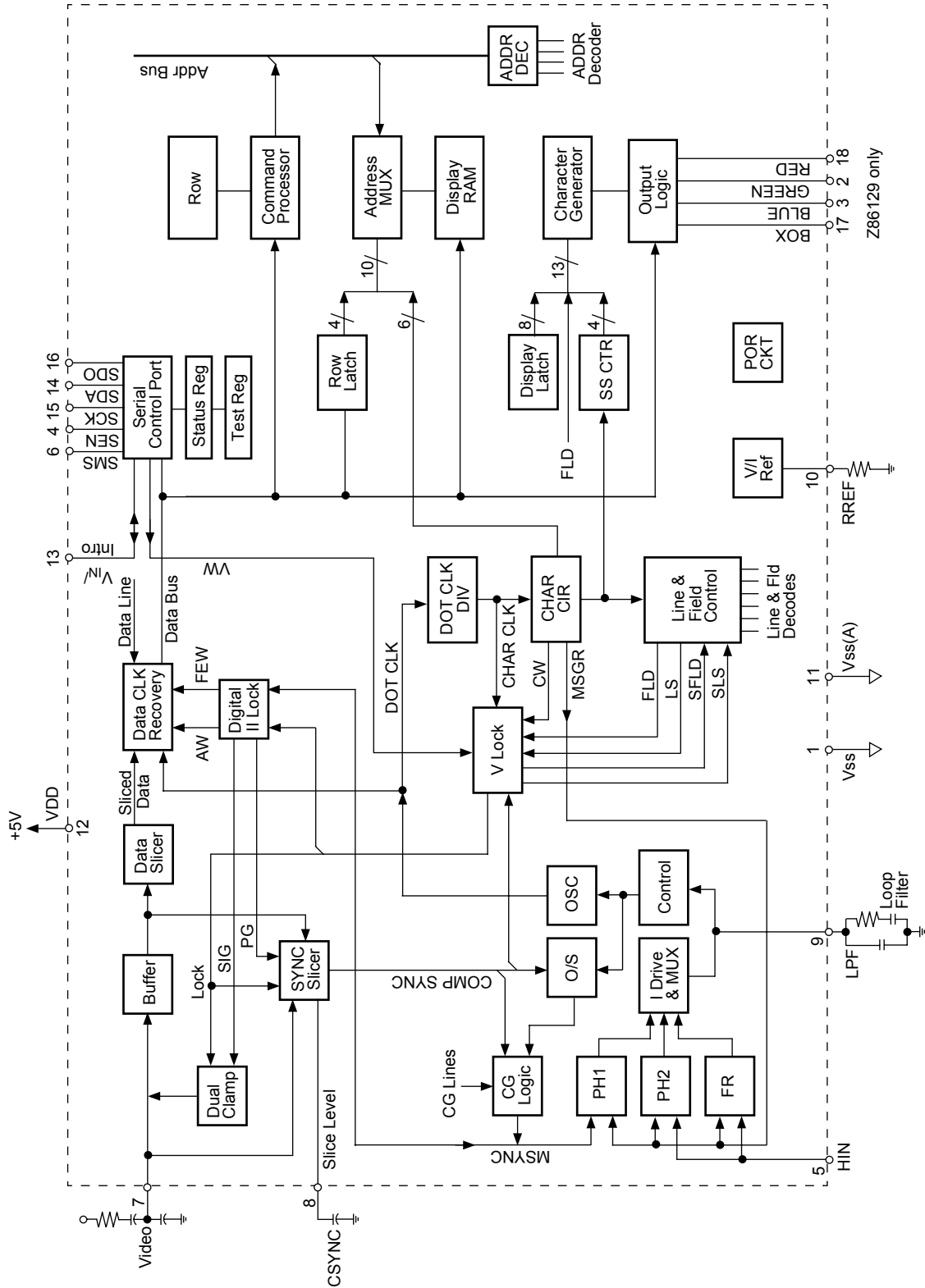


Figure 1. Z86129 Block Diagram

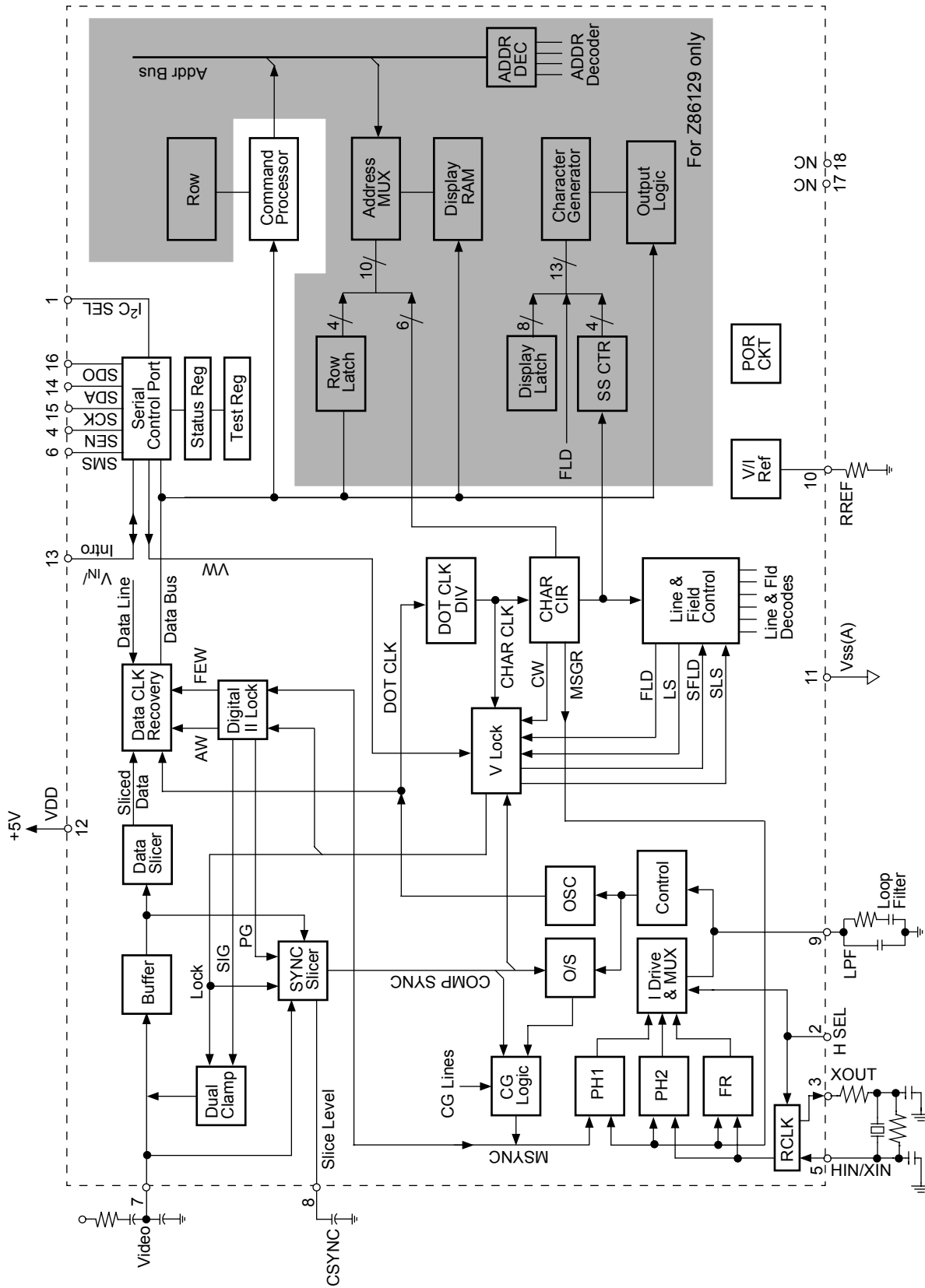
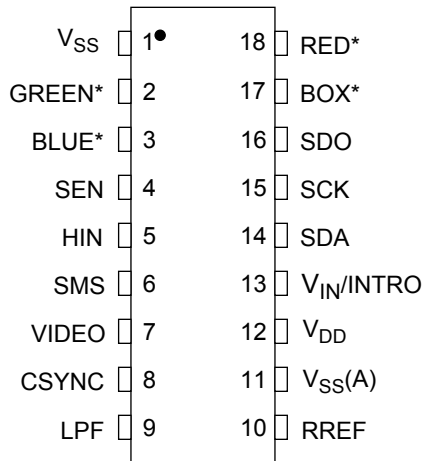
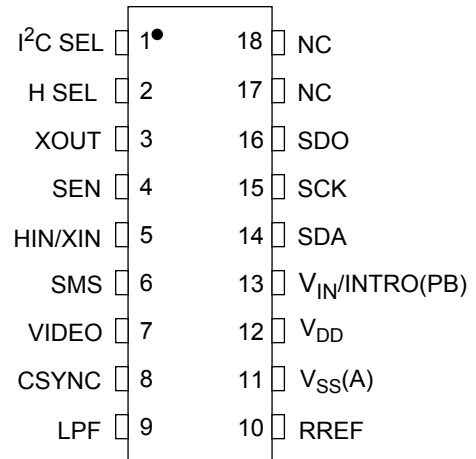


Figure 2. Z86130/131 Block Diagram

**PIN DESCRIPTION**



**Figure 3. Z86129, 18-Pin DIP/SOIC Pin Configuration**



**Figure 4. Z86130/131, 18-Pin DIP/SOIC Pin Configuration**

**Table 1. Z86129 Pin Identification**

No	Symbol	Function	Direction
1	V <sub>SS</sub>	Power Supply GND	
2*	GREEN	Video Output	Output
3*	BLUE	Video Output	Output
4	SEN	Serial Enable	Input
5	HIN	Horizontal In	Input
6	SMS	Serial Mode Select	Input
7	VIDEO	Composite Video	Input
8	CSYNC	Composite Sync	Output
9	LPF	Loop Filter	Output
10	RREF	Resistor Reference	Input
11	V <sub>SS(A)</sub>	Pwr. Supply (Analog) GND	
12	V <sub>DD</sub>	Power Supply	
13	V <sub>IN</sub> /INTRO	Vertical In/Interrupt Out	In/Output
14	SDA	Serial Data	In/Output
15	SCK	Serial Clock	Input
16	SDO	Serial Data Out	Output
17*	BOX	OSD Timing Signal	Output
18*	RED	Video Output	Output

**Note:** \*DIP and SOIC pin configuration are identical.

**Table 2. Z86130/131 Pin Identification**

No	Symbol	Function	Direction
1*	I <sup>2</sup> C SEL	I <sup>2</sup> C Slave Address Select	Input
2	H SEL	HIN/XTAL Select	Input
3	XOUT	XTAL Output	Output
4	SEN	Serial Enable	Input
5	HIN/XIN	Horizontal In/XTAL Input	Input
6	SMS	Serial Mode Select	Input
7	VIDEO	Composite Video	Input
8	CSYNC	Composite Sync	Output
9	LPF	Loop Filter	Output
10	RREF	Resistor Reference	Input
11	V <sub>SS(A)</sub>	Pwr. Supply (Analog) GND	
12	V <sub>DD</sub>	Power Supply	
13**	V <sub>IN</sub> /INTRO (PB)	Vertical In/Interrupt Out (Program Blocking)	In/Output (Output)
14	SDA	Serial Data	In/Output
15	SCK	Serial Clock	Input
16	SDO	Serial Data Out	Output
17	NC	No Connect	
18	NC	No Connect	

**Notes:**

\*DIP and SOIC pin configuration are identical; must be tied to V<sub>SS</sub> for current revision. A secondary I<sup>2</sup>C address will be available in the future.

\*\*This pin is used as PB (Program Blocking) output in Z86130 to indicate whether the incoming video program is in the blocking set-up programmed.

**ABSOLUTE MAXIMUM RATINGS\***

Symbol	Parameter	Value	Unit
$V_{DD}$	DC Supply Voltage**	-0.5 to 6.0	V
$V_{IN}$	DC Input Voltage**	-0.5 to $V_{DD} + 0.5$	V
$V_{OUT}$	DC Output Voltage**	-0.5 to $V_{DD} + 0.5$	V
$I_{IN}$	DC Input Current per Pin	+10	mA
$I_{OUT}$	DC Output Current per Pin	+20	mA
$I_{DD}$	DC Supply Current	+30	mA
$P_D$	Power Dissipation per Device	300	mW
$T_{STG}$	Storage Temperature	-65 to +150	°C
$T_L$	Lead Temperature, 1 mm from Case for 10 seconds	260	°C

**Notes:**

\*Maximum ratings are those values beyond which damage to the device may occur. Functional operation should be restricted to the limits specified in the DC and AC Characteristics tables, pages 5 and 6, or the Pin Description section, page 9.

\*\*Voltages referenced to  $V_{SS(A)}$  and  $V_{SS}$ .

**STANDARD TEST CONDITIONS**

The characteristics listed in the following section apply for standard test conditions as noted. All voltages are referenced to Ground. Positive current flows into the referenced pin (5).

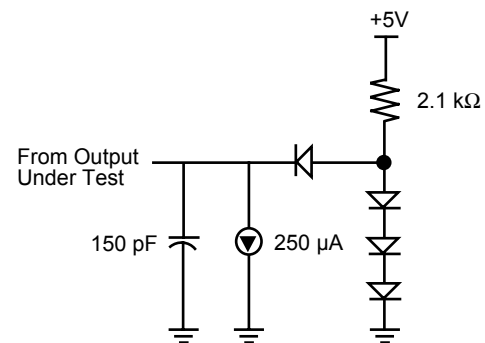


Figure 5. Standard Test Load

**DC ELECTRICAL CHARACTERISTICS**

Table 3. DC Electrical Characteristics  
( $T_A = 0^\circ\text{C}$  to  $+70^\circ\text{C}$ ;  $V_{DD} = +4.75\text{V}$  to  $+5.25\text{V}$ )

Symbol	Parameter	Conditions	Min	Max	Unit
$V_{IL}$	Input Voltage Low		0	$0.2 V_{DD}$	V
$V_{IH}$	Input Voltage High		$0.7 V_{DD}$	$V_{DD}$	V
$V_{OL}$	Output Voltage Low	$I_{OL} = 1.00 \text{ mA}$	-	0.4	V
$V_{OH}$	Output Voltage High	$I_{OH} = 0.75 \text{ mA}$	$V_{DD} - 0.4\text{V}$	-	V
$I_{IL}$	Input Leakage	$0\text{V}, V_{DD}$	-3.0	3.0	$\mu\text{A}$
$I_{DD}$	Supply Current	Estimated*		30	mA
Kf	VCO Gain		-	TBD	MHz/V
$I_{LP}$	Loop Filter Current		-	TBD	mA

**Note:** \*Not guaranteed.

## AC AND TIMING CHARACTERISTICS

**Table 4. Composite Video Input**

Parameter	Conditions
Amplitude	1.0V p-p $\pm 3$ dB
Polarity	Sync tips negative
Bandwidth	600 kHz
Signal Type	Interlaced
Max Input R	470 ohms
DC Offset	Signal to be AC coupled with a minimum series capacitance of 0.1 $\mu$ F

## ELECTRICAL CHARACTERISTICS

Nonstandard Video Signals must exhibit the characteristics indicated in Table 5.

**Table 5. Characteristics**

Parameter	Conditions
Sync Amplitude	200 mV minimum
Vertical Pulse Width	3H $\pm 0.5$ H
Vertical Pulse Tilt	20 mV maximum
H Timing	Phase Step (Head Switch) $\pm 10$ $\mu$ s maximum Fh Deviation (long term) $\pm 0.5\%$ maximum Fh p-p Deviation (short term) $\pm 0.3\%$ maximum
Vertical Sync Signal	The internal sync circuits lock to all 525 or 625 line signals having a vertical sync pulse that meets the following conditions: <ul style="list-style-type: none"> <li>• It is at least 2H wide</li> <li>• It starts at the proper 2H boundary for its field</li> <li>• If equalizing pulse serrations are present, they must be less than 0.125H in width.</li> </ul>
Minimum Signal-to-Noise	The Z86129/130/131 functions down to a 25 dB signal-to-noise ratio (CCIR-weighted) with one error per row or better at that level.
Ratio to Composite Video	Input

Horizontal Signal Input (preferably H Flyback and refer to 1 and 2 to use external XTAL or clock input for Z86130/131 only)

**Table 6. Horizontal Signal Input**

Parameter	Conditions
Amplitude	CMOS level signal where Low $\leq 0.2 V_{CC}$
Video Lock Mode	Polarity Any Frequency 15,734.263 Hz $\pm 3\%$
HIN Lock Mode	Polarity Any Frequency Same as Display Horizontal Flyback Pulse (HFB) pulse

**Table 7. XTAL Input on HIN/XIN and XOUT—Z86130/131 Only**

Parameter	Conditions
Frequency	32.768 KHz
Frequency tolerance	+/- 20ppm @ Ta=25C, CL=12.5pF
Equivalent XTALs	Epson C-001R 32.768K-A or Fox NC26, NC28

**Table 8. Clock Input on HIN/XIN—Z86130/131 Only**

Parameter	Conditions
Frequency	32.768 kHz +/- 2%

## Line 21 Input Parameters (at 1.0V p-p)

**Note:** Line 21 must be in its proper position to the leading edge of the Vertical Sync signal.

**Table 9. Line Input Parameters**

Parameter	Conditions
Cod Amplitude	50 IRE
Code Zero Level	5 IRE, +15 IRE relative to Back Porch
Start of Code	10.5 ±0.5 μs (measured from the midpoint of the falling edge of the most recent clock run-in cycle to the midpoint of the rising edge of the start bit).
Start of Data	3.972 μs, -0.00 μsec, +0.30 μs (measured from the midpoint of the falling edge of the most recent clock run-in cycle to the midpoint of the rising edge of the start bit).

## Timing Signals

**Table 10. Timing Signals**

Parameter	Conditions
Dot	768 x FH = 12.0839 MHz
Dot Period	82.75 ns
Character Cell Width	1.324 μs (tH/48)
Width of Row (Box)	45.018 μs (34 chars = 17/24 x tH)
Width of Row (Char)	42.370 μs (32 chars = 2/3 x tH)
Horizontal Display Timing	The timing of the output signals Box and RGB have been set to make a centered display. The positioning of these outputs can be adjusted in 330 ns increments by writing a new value to the Z86129 H Position Register (Address = 02h).

## PIN DESCRIPTIONS (Z86129 ONLY)

### Inputs

**VIDEO (Pin 7).** Composite NTSC video input, 1.0V p-p (nom), band limited to 600 kHz. The circuit operates with signal variation between 0.7–1.4V p-p. The polarity is sync tips negative. This signal pin should be AC coupled through a 0.1  $\mu$ F capacitor and driven by a source impedance of 470 ohms or less.

**HIN (Pin 5).** Horizontal Sync input signal at CMOS level must be supplied. When the device is used in VIDEO LOCK mode, this signal pulls the on-chip VCO within the proper range. The circuit uses the frequency of this signal which must be within  $\pm 3\%$   $F_h$  but can be of either polarity. When used in the H LOCK mode, the VCO phase locks to the rising edge of this signal. The HPOL bit of the H Position register can be set to operate with either polarity of input signal (usually the H Flyback signal). The timing difference between HIN rising edge and the leading edge of composite sync (of VIDEO input) is one of the factors which affects the horizontal position of the display. Any shift resulting from the timing of this signal can be compensated for with the horizontal timing value in H Position Register. H LOCK is intended for use when the part is generating an OSD display when no video signal is present.

**SMS (Pin 6).** Mode select pin for the Serial Control Port. When this input is at a CMOS High state (1) the Serial Control Port operates in the SPI mode. When the input is Low (0), the Serial Control Port operates in the I<sup>2</sup>C slave mode. In SPI mode, the SEN pin must be tied High. (See Reset Operation section, below.)

**SEN (Pin 4).** Enable signal for the SPI mode operation of the Serial Control Port. When this pin is Low (0), the SPI port is disabled and the SDO pin is in the high-impedance state. Transitions on the SCK and SDA pins are ignored. SPI mode operation is enabled when SMS is High (1).

**SCK (Pin 15).** Input pin for serial clock signal from the master control device. In I<sup>2</sup>C mode operation the clock rate is expected to be within I<sup>2</sup>C limits. In SPI mode, the maximum clock frequency is 10 MHz.

**Reset Operation.** When the SMS and SEN pins are both in the Low (0) state, the part is in the Reset state. Therefore, in the I<sup>2</sup>C mode the SEN pin can be used as an NReset input. When SPI mode is used, if three wire operation is desired, both SMS and SEN can be tied together and used as the NReset input. In either mode, NReset must be held Low (0) for at least 100 ns.

### Input/Output

**V<sub>IN</sub>/INTRO (Pin 13).** In external (EXT) vertical lock mode of operation, the internal vertical sync circuits lock to the V<sub>IN</sub> input signal applied at this pin. The part locks to the rising or falling edge of the signal in accordance with the setting of the V Polarity command. The default is rising edge. The V<sub>IN</sub> pulse must be at least 2 lines wide.

In INTRO Mode, when configured for internal vertical synchronization, this pin is an output pin providing an interrupt signal to the master control device in accordance with the settings in the Interrupt Mask Register.

**SDA (Pin 14).** When the Serial Control Port has been set to I<sup>2</sup>C mode operation, this pin serves as the bidirectional data line for sending and receiving serial data. In SPI mode operation it operates as serial data input. SPI mode output data is available on the SDO pin.

### Outputs

**SDO (Pin 16).** Provides the serial data output when SPI mode communications have been selected. This pin is not used in I<sup>2</sup>C mode operation.

**Box (Pin 17).** Black box keying output is an active High, CMOS level signal used to key in the black box in the captions/text displays. This output is in the high-impedance state when the background attribute is set to semi-transparent.

**RED, GREEN, BLUE (Pins 2, 3, 18).** Positive acting CMOS levels signals.

Color Mode: Red, Green and Blue character video outputs for use in a color receiver.

- Mono Mode: All three outputs carry the character luminance information

---

**Note:** The selection of Color/Mono Mode is user controlled in bit D<sub>1</sub> of the Configuration Register (Address=00h). (See Internal Registers section, page 33).

---

**CSync (Pin 8).** Sync slice level. A 0.1- $\mu$ F capacitor must be tied between this pin and analog ground V<sub>SS(A)</sub>. This capacitor stores the sync slice level voltage.

**LPF (Pin 9).** Loop Filter. A series RC low-pass filter must be tied between this pin and analog ground V<sub>SS(A)</sub>. There must also be second capacitor from the pin to V<sub>SS(A)</sub>.



**RREF (Pin 10).** Reference setting resistor. Resistor must be 10 kOhms,  $\pm 2\%$ .

## Power Supply

**V<sub>DD</sub> (Pin 12).** The voltage on this pin is nominally 5.0 Volts and may range between 4.75 to 5.25 Volts with respect to the V<sub>SS</sub> pins.

**V<sub>SS</sub> (Pins 1, 11).** These pins are the lowest potential power pins for the analog and digital circuits. They are normally tied to system ground.

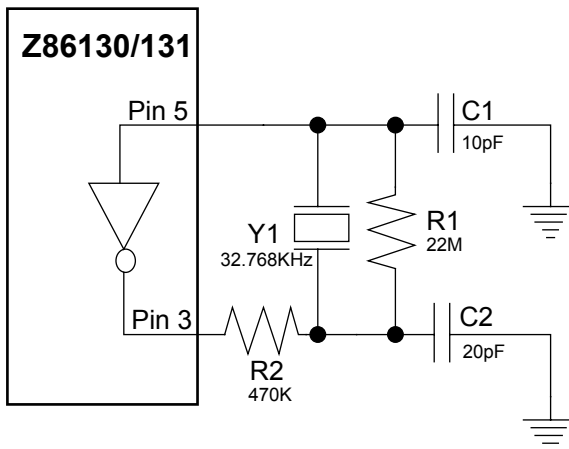
**Note:** The recommended printed circuit pattern for implementing the power connection and critical components is in the Application Information section, page 58.

## PIN DESCRIPTIONS (Z86130/131 ONLY)

### Inputs

**VIDEO (Pin 7).** Composite NTSC video input, 1.0V p-p (nom), band limited to 600 kHz. The circuit operates with signal variation between 0.7–1.4V p-p. The polarity is sync tips negative. This signal pin should be AC coupled through a 0.1  $\mu$ F capacitor and driven by a source impedance of 470 ohms or less.

**HIN/XIN (Pin 5).** This pin can function in two different modes. When XTAL mode has been selected (see HIN description below) the horizontal sync signal is generated on the chip using an external 32.768-kHz crystal circuit, as illustrated below. This circuit must be connected between pin 5 and 3.



Crystal Type: 32.768 kHz, CL=12.5pF  
Series Resistance < 35 kOhms  
(18 kOhms typ)  
Epson, C-001R 32.768 kHz or  
Fox, NC26, NC28 or equivalent

**Figure 6. XTAL Circuit**

When HIN mode has been selected a Horizontal Sync input signal at CMOS level must be supplied to pin 5. When the device is used in VIDEO LOCK mode, this signal pulls the on-chip V<sub>CO</sub> within the proper range. The circuit uses the

frequency of this signal which must be within  $\pm 3\%$  F<sub>h</sub> but can be of either polarity. When used in the H LOCK mode, the V<sub>CO</sub> phase locks to the rising edge of this signal. The HPOL bit of the H Position register can be set to operate with either polarity of input signal (usually the H Flyback signal).

**SMS (Pin 6).** Mode select pin for the Serial Control Port. When this input is at a CMOS High state (1) the Serial Control Port operates in the SPI mode. When the input is Low (0), the Serial Control Port operates in the I<sup>2</sup>C slave mode. In SPI mode, the SEN pin must be tied High. (See Reset Operation section, below.)

**SEN (Pin 4).** Enable signal for the SPI mode operation of the Serial Control Port. When this pin is Low (0), the SPI port is disabled and the SDO pin is in the high-impedance state. Transitions on the SCK and SDA pins are ignored. SPI mode operation is enabled when SMS is High (1).

**SCK (Pin 15).** Input pin for serial clock signal from the master control device. In I<sup>2</sup>C mode operation the clock rate is expected to be within I<sup>2</sup>C limits. In SPI mode, the maximum clock frequency is 10 MHz.

**I<sup>2</sup>C SEL (Pin 1).** Tying this pin Low selects the Slave Read Address 29h and the Slave Write Address 28h. Tying this pin High selects the alternate Slave Address but it is not available in the current version.

**H SEL (Pin 2).** It selects the source of the Horizontal Sync signal. Tying pin 2 High selects the XTAL mode. The 32.768-kHz crystal circuit must be connected between pins 5 & 3. Tying pin 2 Low selects HIN mode operation. The appropriate Horizontal Sync signal must be supplied to pin 5.

**Reset Operation.** When the SMS and SEN pins are both in the Low (0) state, the part is in the Reset state. Therefore, in the I<sup>2</sup>C mode the SEN pin can be used as an NReset input. When SPI mode is used, if three wire operation is desired, both SMS and SEN can be tied together and used as the

## PIN DESCRIPTIONS (Z86130/131 ONLY) (Continued)

NReset input. In either mode, NReset must be held Low (0) for at least 100 ns.

### Input/Output

**V<sub>IN</sub>/INTRO (PB:Z86130 only; Pin 13).** This pin can be used as V<sub>IN</sub>/INTRO for Z86131. It is a dedicated output pin, PB (Program Blocking), in Z86130.

In the Z86130, as described in the Input section, PB output is High for indicating the incoming video program is in the program blocking set-up.

In the Z86131, this pin is an output providing an interrupt signal to the master control device in accordance with the settings in the interrupt Mask Register.

**SDA (Pin 14).** When the Serial Control Port has been set to I<sup>2</sup>C mode operation, this pin serves as the bidirectional data line for sending and receiving serial data. In SPI mode operation it operates as serial data input. SPI mode output data is available on the SDO pin.

### Outputs

**SDO (Pin 16).** Provides the serial data output when SPI mode communications have been selected. This pin is not used in I<sup>2</sup>C mode operation.

**PB (Pin 13).** This pin is for the Z86130 only and refer to V<sub>IN</sub>/INTRO(PB) descriptions in the Input/Output section above.

**XOUT (Pins 3).** This pin is XTAL output. It is be NC (No connect for inputting 32.768-kHz frequency from external device.

**CSync (Pin 8).** Sync slice level. A 0.1- $\mu$ F capacitor must be tied between this pin and analog ground V<sub>SS(A)</sub>. This capacitor stores the sync slice level voltage.

**LPF (Pin 9).** Loop Filter. A series RC low-pass filter must be tied between this pin and analog ground V<sub>SS(A)</sub>. There must also be second capacitor from the pin to V<sub>SS(A)</sub>. Values for the three parts to be specified at a later date.

**RREF (Pin 10).** Reference setting resistor. Resistor must be 10 kohms,  $\pm 2\%$ .

**NC.** No Connect

**Pin 17, 18.** These pins are NC (No Connect).

### Power Supply

**V<sub>DD</sub> (Pin 12).** The voltage on this pin is nominally 5.0 Volts and may range between 4.75 to 5.25 Volts with respect to the V<sub>SS</sub> pins.

**V<sub>SS</sub> (Pins 11).** These pins are the lowest potential power pins for the analog and digital circuits. They are normally tied to system ground.

---

**Note:** The recommended printed circuit pattern for implementing the power connection and critical components is in the Application Information section, page 58.

---

## Z86129/130/131 BLOCK DIAGRAM DESCRIPTION

As discussed, the Z86129/130/131 are defined differently for the requirements of Line 21 Data applications. However the part number, Z86129, is used to describe the functions of the block diagram. In this description, there are some descriptions that are not applicable to the Z86130/131 for the feature differences listed on page 1.

The Z86129 is designed to process both fields of Line 21 of the television VBI and provide the functional performance of a Line 21 Closed-Caption decoder and Extended Data Service decoder. It requires two input signals, Composite Video and a horizontal timing signal (HIN), and several passive components for proper operation. A vertical input signal is also required if OSD display mode is desired when no video signal is present. The Decoder performs several functions, namely extraction of the data from Line 21, separation of the normal Line 21 data from the XDS data, on-screen display (Z86129 only) of the selected data channel and outputting of the XDS data through the serial communications channel.

### Input Signals

The Composite Video input should be a signal which is nominally 1.0 Volt p-p with sync tips negative and band limited to 600 kHz. The Z86129 operates with an input level variation of  $\pm 3$  dB.

The HIN input signal is required to bring the VCO close to the desired operating frequency. It must be a CMOS level signal. The HIN signal can have positive or negative polarity and is only required to be within 3% of the standard H frequency. When configured for EXT HLK operation, this signal should correspond to the H Flyback signal.

The timing difference between HIN rising edge and the leading edge of composite sync (of VIDEO input) is one of the factors that affects the horizontal position of the display. Any shift resulting from the timing of this signal can be compensated for with the horizontal timing value in the H Position register.

### Video Input Signal Processing

The Comp Video input is AC coupled to the device where the sync tip is internally clamped to a fixed reference voltage by means of a dual clamp. Initially, the unlocked signal is clamped using a simple clamp. Improved impulse noise performance is then achieved after the internal sync circuits lock to the incoming signal. Noise rejection is obtained by making the clamp operative only during the sync tip. The clamped composite video signal is fed to both the Data Slicer and Sync Slicer blocks.

The Data Slicer generates a clean CMOS level data signal by slicing the signal at its midpoint. The slice level is established on an adaptive basis during Line 21. The resultant value is stored until the next occurrence of that Line 21. A high level of noise immunity is achieved by using this process.

The Sync Slicer processes the clamped Comp Video signal to extract Comp Sync. This signal is used to lock the internally generated sync to the incoming video when the video lock mode of operation has been enabled. Sync slicing is performed in two steps. In the non-locked mode, the sync is sliced at a fixed offset level from the sync tip. When proper lock operation has been achieved, the slice level voltage switches from a fixed reference level to an adaptive level. The slice level is stored on the sync slice capacitor, CSYNC.

The Data Clock Recovery circuit operates in conjunction with the Digital H Lock circuit. They produce a 32H clock signal (DCLK) that is locked in phase to the clock run-in burst portion of the sliced data obtained from the Data Slicer. When Line 21 code appears, DCLK phase lock is achieved during the clock run-in burst and used to relock the sliced data. After phase lock is established it is maintained until a change in video signal occurs.

The Digital H Lock circuit produces the video timing gates, PG, STG, and so on, which are locked in phase with HSYNC, the video timing signal, no matter which H lock mode is used in the display generation circuits. This independent phase lock loop is able to respond quickly to changes in video timing, without concern for display stability requirements.

### VCO and One Shot

All internal timing and synchronizing signals are derived from the on-board 12-MHz VCO. Its output is the Dot Clk signal used to drive the Horizontal and Vertical counter chains and for display timing. The One Shot circuit produces a horizontal timing signal derived from the incoming video and qualified by the Copy Guard logic circuits.

The VCO can be locked in phase to two different sources. For television operation, where a good horizontal display timing signal is available, the VCO is locked to the HIN input through the action of the Phase Detector (PH2). When a proper HIN signal is not available, such as in a VCR, the VCO can be locked to the incoming video through the Phase Detector (PH1). In this case, the frequency detector (FR) circuit is activated as required to bring the VCO within the pull-in range of PH1.

## Z86129/130/131 BLOCK DIAGRAM DESCRIPTION (Continued)

### Timing and Counting Circuits

The Dot Clk is first divided down to produce the character timing clock CHAR CLK. This signal is then further divided to generate the horizontal timing signals, H, 2H and HSQR. These timing signals are used in the data output (display) circuits.

The H signal is further divided in the LINE and FLD CNTR to produce the various decodes used to establish vertical lock and to time the display and control functions required for proper operation. The H signal is also used to generate the Smooth Scroll timing signal for display.

The V Lock circuits produce a noise free vertical pulse derived from the horizontal timing signal. When the user selects Video as the vertical lock source, the internal synchronizing signals are phased up with the incoming video by comparing the internally generated vertical pulse to an input vertical pulse derived from the Comp Sync signal provided by the Sync Slicer. In the vertical lock set to  $V_{IN}$  mode the  $V_{IN}$  signal is used in place of the signal derived from Comp Sync. In either case, when proper phasing has been established, this circuit outputs the LOCK signal which is used to provide additional noise immunity to the slicing circuits.

The LOCKed state is established only after several successive fields have occurred in which these two vertical pulses remain in sync. When LOCKed, the internal timing flywheels until such time as the two vertical pulses lose coincidence for a number of consecutive fields. Until LOCK is established, the decoder operates on a pulse for pulse basis.

### Command Processor

The Command Processor circuit controls the manipulation of the data for storage and display. It processes the Control Port input commands to determine the display status desired and the data channel selected. During the display time (lines 43–237), this information is used to control the loading, addressing and clearing of the Display RAM and the operations of the Character ROM and Output Logic circuits.

During data recovery time (TV lines 21–42), the Command Processor, in conjunction with the data recovery circuits, recovers the XDS data and the data for the selected data channel. Data is sent to the RAM for storage and display and/or to the serial port, as appropriate. Where necessary, the Command Processor converts the input data to the appropriate form.

### Output Logic (Z86129 only)

The output logic circuits operate together to generate the output color signals RED, GREEN and BLUE and the Box signal. When MONOchrome mode is selected all three color outputs carry the Luminance information. These outputs are positive output logic signals.

The character ROM contains the dot pattern for all the characters. The output logic provides the hardware underline, graphics characters and the Italics slant generator circuits. The smooth scroll display is achieved by the smooth scroll counter logic controlling the addressing of the Character ROM.

### Decoder Control Circuit

The Decoder Control circuit block is the users communications port. It converts the information provided to the control port into the internal control signals required to establish the operating mode of the decoder. This port can be operated in one of two serial modes. The SMS pin is used to establish the serial control mode to be used.

In the two-wire ( $I^2C$ ) control mode, the Z86129/130/131 respond to its slave address for both the read and write conditions. If the read bit is Low (indicating a WRITE sequence) then the Z86129/130/131 responds with an acknowledge. The master should then send an address byte followed by a data byte. If the read bit is High (indicating a READ sequence) then the Z86129/130/131 responds with an acknowledge followed by a status byte then a data byte. Read data is only available through indirect addressing. Write addressing exhibits both indirect and direct modes. The busy bit in the status byte indicates if the write operation has been completed or if read data is available.

The SPI mode is a three wire bus with the Z86129/130/131 performing as the slave device. Communication is synchronized by the SCK signal generated by the master. Typically, the serial data output is transmitted on the falling edge of SCK and the received data is captured on the rising edge of SCK. All data is exchanged as 8-bit bytes.

### Voltage/Current Reference

The Voltage/Current reference circuit uses an externally connected resistor to establish the reference levels that are used throughout the Z86129/130/131. The use of an external resistor provides improved internal precision at minimal additional cost.

## Z86129/130/131 FUNCTIONAL DESCRIPTION

As discussed, the Z86129/130/131 are defined differently for the requirements of Line 21 Data applications. However the part number, Z86129, is used for the Z86129/130/131 functional descriptions. In this description, there are some descriptions that are not applicable to the Z86130/131 for the feature differences listed on page 1.

The Z86129 provides full function NTSC, Line 21 performance. Input commands are included to enable the decoder to process and display any of the eight Caption/Text data channels (CC1, CC2, CC3, CC4, T1, T2, T3 or T4) contained in Line 21 of either field of the incoming video. XDS data can also be selected for display. The DECODER ON/OFF commands control whether or not the Line 21 data in the selected channel is actually displayed. When switched to the DECODER OFF (TV) state, incoming data in the selected channel is still processed, but not displayed.

The Z86129/130/131 can also be configured to operate with PAL or SECAM video signals. It decodes information encoded into its VBI in Line 22. The encoded data must conform to the waveform and command structure defined for NTSC Line 21 operation.

### VCO Lock

The design includes a VCO with stable gain characteristics and good power supply rejection. The internal horizontal and vertical synchronizing circuits provide a high degree of noise immunity. There are options for both horizontal and vertical lock. The VCO can be phase locked either to the horizontal signal derived from the video input signal (VIDEO) or to the externally supplied HIN signal, typically horizontal flyback.

HIN lock is used to provide a display having a minimum of observable jitter. This condition requires an HIN signal derived from the TV display and of the proper polarity. Such a signal is readily available in a television receiver. VIDEO lock mode enables the VCO to lock in phase to the incoming video signal, thus providing good operation in an application where no display related HIN signal is available, such as in a VCR.

### Video Timing

Timing signals are derived from the VCO for use in the line counting and display circuits. Line counting requires proper identification of the input signal's vertical pulse. Default operation uses the vertical sync signal derived from the video input signal as the source for vertical lock. This method results in locking characteristics having good performance and good noise immunity.

In the event that OSD operation is required under conditions when no input video is present, it would be necessary to set the Z86129 for  $V_{IN}$  lock. In this mode, the vertical timing is determined from the vertical pulse signal supplied to the  $V_{IN}$  pin.

The horizontal position of the caption display is determined by the internal timing circuits. A default condition has been established that should result in a well centered display in a typical application. However, because signal delays through video processing circuits can vary between designs, the Z86129 provides the user with the ability to change the default timing. No matter which of the horizontal lock modes are selected, the display horizontal position on the screen can be adjusted in quarter character (330 ns) steps by serial port commands.

### Displayable Character Set (Z86129 only)

**Normal Mode.** Characters are displayed as white or colored dot matrix characters on an opaque background. The Box is normally black but the Z86129 can be set to a blue background Box with a serial command. The characters are described by a 12 by 18 dot pattern within a character cell which is 16 dots wide by 26 dots high per frame. The location of the character luminance within the character cell varies from character to character to allow for the display of lower case letters with descenders. All characters have at least a 1-dot border of black around each character. Underline is also provided. Figure 7 illustrates the Z86129 standard character map and font.

The character ROM consists of a 12 by 18 dot matrix pattern per character. Alternate rows and columns are read out in each field to produce an interleaved and rounded character. A display row contains a maximum of 32 characters plus a leading and trailing black box, each a character cell in width, making the overall width of a display row  $34 \times 8 = 272$  dots. Successive display rows are butted together so that the total display occupies 195 dots high.

The black box 34 character cells wide by 195 dots high results in a box size of  $45.018 \mu\text{s}$  in width by 195 scan lines in height. The Box starts in scan line 43 and extends to scan line 237. Theoretically, the display is horizontally centered in the video display when the Box starts  $13.2 \mu\text{s}$  after the leading edge of H.

The default setting of the Z86129 places the center of the Box at about  $13.5 \mu\text{s}$  to allow for some delay in the normal video path. However, the Box horizontal position can be adjusted by the user in 330 ns increments. The display is approximately within the safe title area for NTSC receivers.

## Z86129/130/131 FUNCTIONAL DESCRIPTION (Continued)

Character width is  $42.37 \mu\text{s}$  also centered on the screen, resulting in a leading and trailing  $1.32 \mu\text{s}$  black border.

An optional Caption display mode, Drop Shadow, can be selected by the user through the serial port. This display mode eliminates the black box around the characters and places a 2-dot black shadow to the right and below the character luminance dots when in the 15 scan line per row mode. This display mode is usable in Captions, Text and OSD displays. Figure 8 illustrates the characters with shadowing added.

### Extended Features

EIA-608 defined new extended features such as optional Background and Foreground display attributes and optional Extended Characters. The Z86129 always responds to the Extended Characters but the Extended Background/Foreground response can be controlled by the user. The Background and Foreground attributes add codes for background colors, black foreground as well as transparent, opaque and semi-transparent background. The BOX signal output pin is set to a tri-state condition whenever one of the semi-transparent attribute codes is active. The external keying circuits can then use this condition to implement the intended video display.

The font for the Extended Characters are illustrated in Figure 9. The accented capital letters have been implemented by placing the accent marks above the character cell. When selected, this mode results in the accent marks being written into the character cell space of the row above. In some op-

erating modes, the Z86129 expands the size of the overall box height by adding two additional scan lines at the top and one additional line at the bottom. This addition makes room for the accent marks in the topmost row and add a black line below the descenders of any lowercase characters in the last row.

This approach is desirable because shrinking the capitals to make room for the accent mark within the character cell makes poor quality characters and in some cases there would be no differentiation between the capital and lower case letter. It also has the advantage of minimizing the ROM size and providing a good readable font that closely matches what is normally seen in print.

In the unlikely case of a conflict between an accented capital letter in one row and a lower case descender in the same character position in the row above, the descender is given priority. The improved readability of this approach over shrunk capital letters far outweighs this potential conflict and results in a cost-effective compromise for providing a full, extended features implementation.

The Extended Characters share their address space with the OSD Graphics Characters. When a BOX display is used the Extended Character set is in force. However, if a Drop Shadow display is used the Graphics Characters are in force. For Caption and Text display modes, if Drop Shadow is set, the user must also command the Z86129 to switch back to Extended Characters.

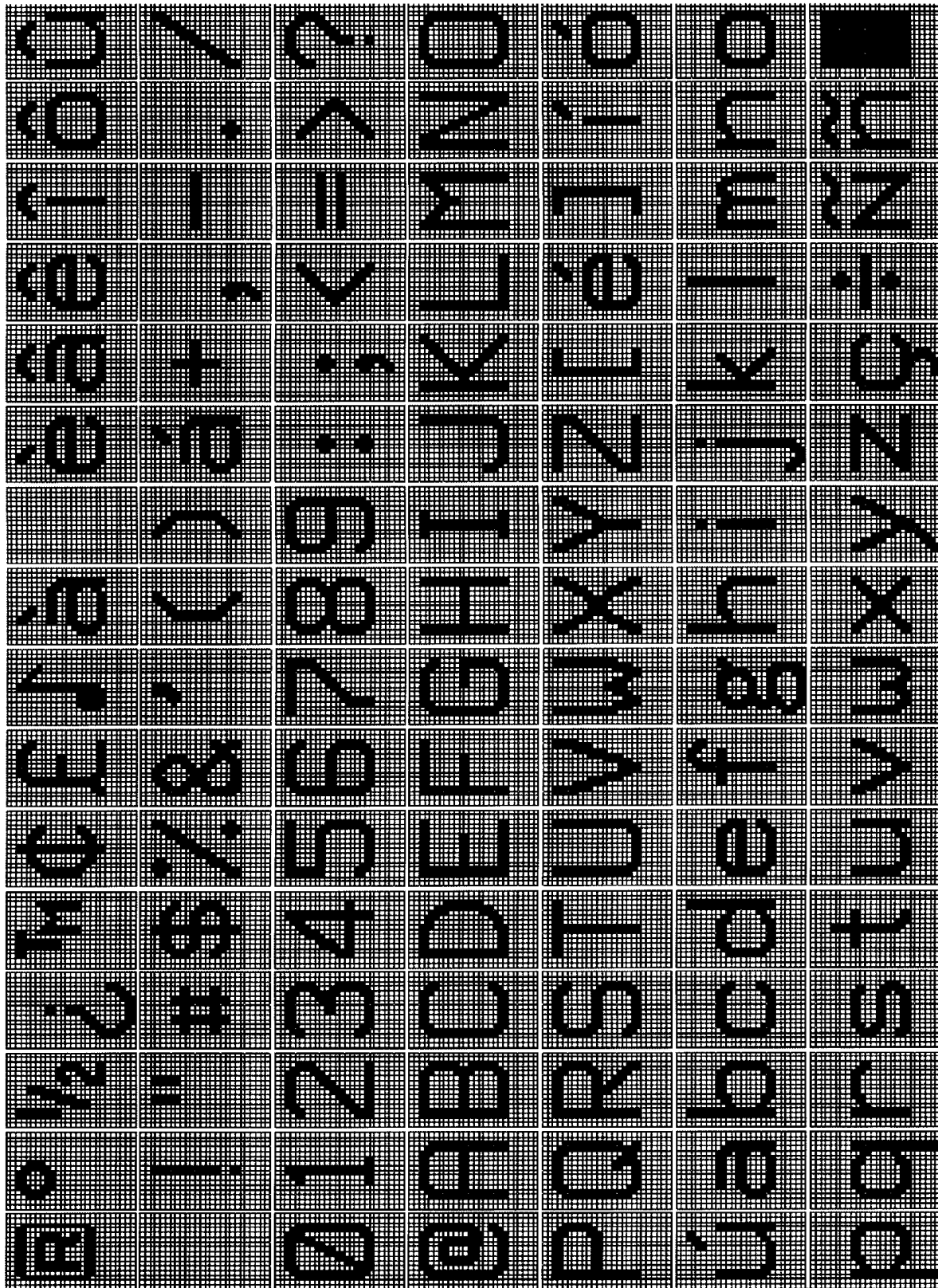


Figure 7. Z86129 Standard Character Map and Font

Z86129/130/131 FUNCTIONAL DESCRIPTION (Continued)



Figure 8. Caption Display Mode, Drop Shadow



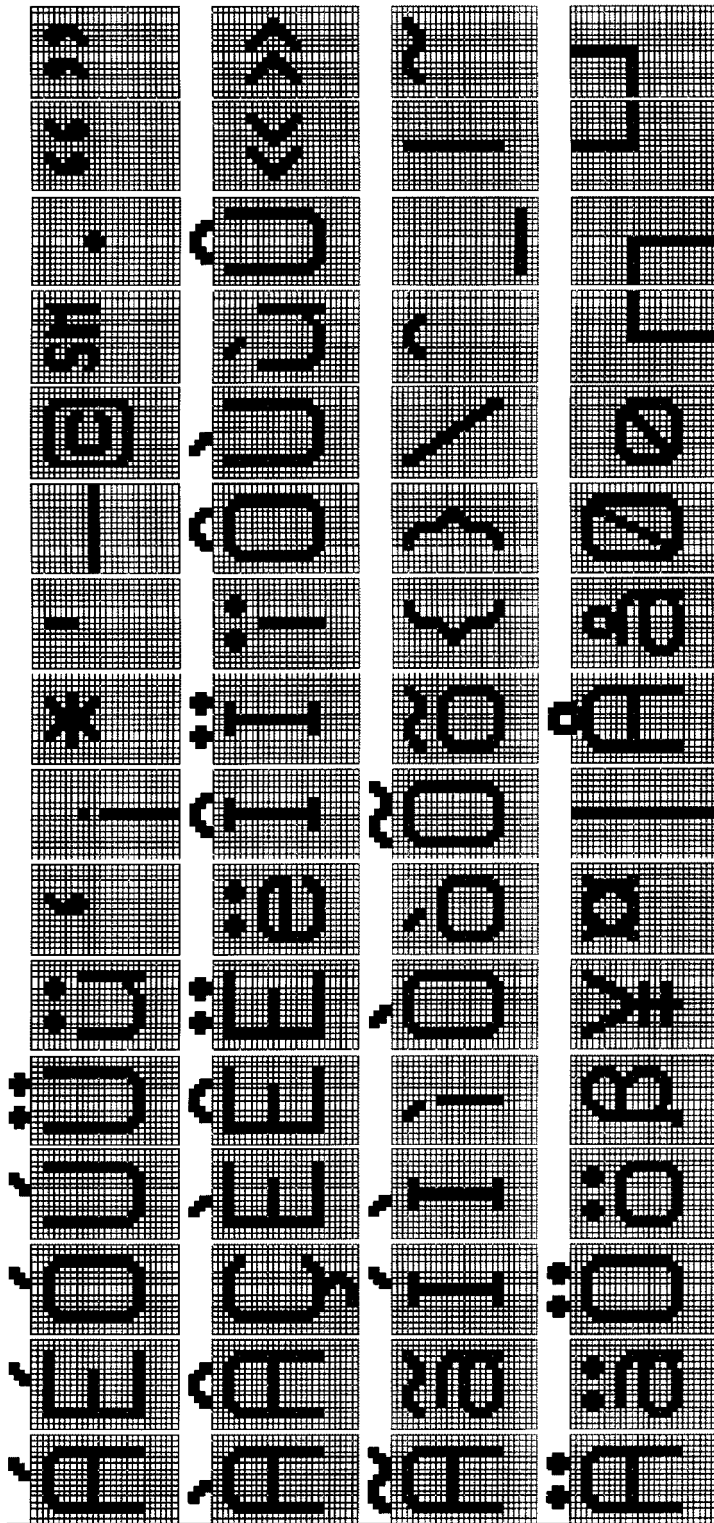


Figure 9. Extended Characters Font

## Z86129/130/131 FUNCTIONAL DESCRIPTION (Continued)

### Text Mode Display (Z86129 Only)

When TEXT mode is selected, a black box is displayed as long as valid Line 21 code in the field selected is being detected. The Z86129 provides the option to make the box blue instead of black. This option holds for Captions as well as Text.

The default TEXT display mode uses a 15 row by 34 character black box. TEXT characters are displayed as they are received starting in the top row. Successive carriage returns move the display down successive rows until all 15 rows have been displayed. Thereafter, the text scrolls up as new characters are added to the bottom row.

If the data for the selected channel is interrupted by a command for another channel, data processing stops, but the display remains. When a Resume Text command is received, data processing resumes and the new characters are added starting at the position that the display row/column pointer was in at the interruption of data processing. If a Start Text command is received, the display is cleared and new characters are displayed starting in row 1, column 1 (left side).

The number of display rows and the location (base row) of the TEXT box, can be altered by the user. In this way, the user can decide how much of the screen can be covered when displaying non-program related information.

When scrolling, the display shifts one scan line per frame until a complete row has been scrolled. If a carriage return is received before scrolling is complete, the display immediately completes the “scroll” by jumping up the remaining scan lines and start displaying the new text.

### Caption Mode Display (Z86129 Only)

According to the FCC specifications Caption data can appear in any of the 15 display rows but a single caption may consist of no more than 4 rows. The form of the caption display depends on the caption mode indicated by the transmitted caption command, Pop-on, Paint-on or Roll-up. The Z86129 can display a single caption having as many as eight rows. When any of the CAPTION display modes have been selected, the screen is transparent. (Display box is only present when a caption is being displayed.)

Pop-on captions work with two caption memories. One of them is normally displayed while the other is being used to accumulate new caption data. A new caption is popped-on by swapping the two memories with the End Of Caption (EOC) command. When the on-screen memory is erased, the screen is blank (transparent) and the memory defaults to the row/column pointer at row 1, column 1 and monochrome non-underlined.

When caption mode is selected, the decoder processes any data following the Resume Caption Loading (RCL) command (or the EOC). Normally, this command is followed by a Preamble Address Code (PAC) to indicate the row, column and character attributes to be used with the following data. If no PAC is received, the data is added to the location most recently indicated by the row/column pointer prior to the receipt of the RCL command.

Paint-on caption mode is essentially equivalent to the Pop-on mode except that the data received after the Resume Direct Captioning (RDC) command is written to the on-screen memory rather than the off-screen memory. All the rules for PACs, Midcodes, and so on, are otherwise the same.

Roll-up caption mode presents a “text” like display that is limited to 2, 3 or 4 rows, depending on the Resume Roll-up (RUn) command used. The PAC following the RUN command is used as the BASE ROW for the ROLL-UP display. The BASE ROW is the “bottom” row of the ROLL-UP display. In this case, the black box does not appear until characters are being displayed and the box is only wide enough to provide a leading and trailing box in each line. The new data appears in the bottom row and as each carriage return is received, the row scrolls up and the new data added to the bottom. When the number of rows indicated by the Resume command has been reached, the data in the top row scrolls off as new data is added to the bottom.

The TAB (INDENT) PAC permits placing Captions starting at 4 character boundaries in any caption row. The TAB OFFSET command provides the means for adjusting the starting position for a Caption at any column position in the current row.

### XDS Display Modes (Z86129 Only)

Two preprogrammed XDS display modes are provided. One provides information about the current program that would be of interest for “channel grazing”. The second display shows the grazing packets plus additional XDS packets which inform the viewer about the program content. Information is displayed as it is received. The displays use drop shadow mode with 15 scan lines per row.

The XDSG mode is the GRAZE (channel grazing) display (Figure 10). The display contains three rows of information at the top of the screen, formatted for easy reading. They contain the following XDS packet information:

---

OSD Row 1	Network Name, Call Letters (Green)
OSD Row 2	Program Name (Italics, Underline, White)
OSD Row 3	Program Length, Time In Show (Cyan)

---

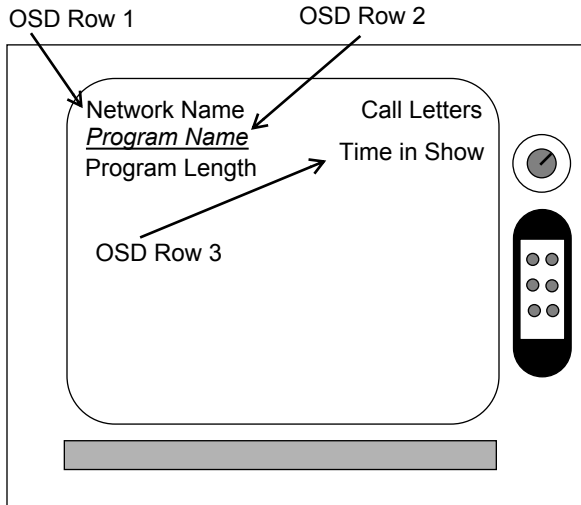


Figure 10. XDSG (Graze) Mode Sample Display

The XDSF mode is the FULL (information) display (Figure 11). This display shows the same information as the GRAZE display and adds the program type as well the first four program description rows (if transmitted). Although XDS defines eight program description rows, the first four are identified as containing the most important information. The display of Program Description is limited to the first four rows because eight rows would obscure much of the screen and because more than four rows is not likely to be sent due to the time required for transmission.

Because 15 scan lines per row mode are being used, rows 10–13 appears at the bottom of the screen.

OSD Row 1	Network Name, Call Letters (Green)
OSD Row 2	Program Name (Italics, Underline, White)
OSD Row 3	Program Length, Program Type, Time In Show (Cyan)
OSD Row 10	Program Description Row 1 (Yellow)
OSD Row 11	Program Description Row 2 (Yellow)
OSD Row 12	Program Description Row 3 (Yellow)
OSD Row 13	Program Description Row 4 (Yellow)

When an XDS display mode has been selected, the information is displayed as the appropriate packets are received. The display remains on-screen as long as valid XDS data continues to be received. If the 16 Second Erase Timer is enabled (the default condition), the XDS display is erased when no valid XDS data has been received for 16 Seconds. If subsequent XDS data is received with displayable pack-

ets, that information reappears on the screen. XDS data recovery can be active in the XDS display mode.

The XDS display mode is turned off by selecting a different display mode.

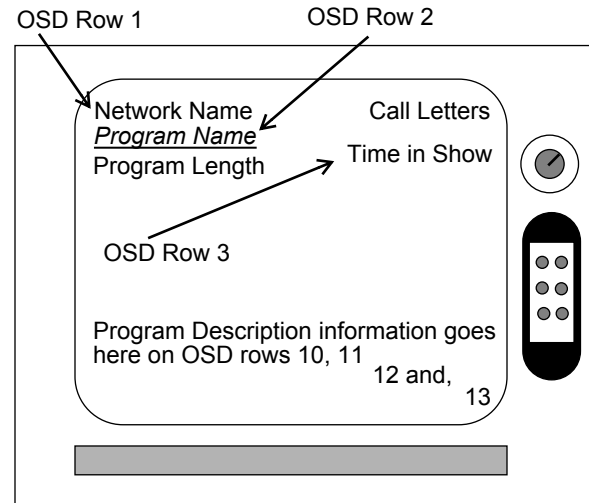


Figure 11. XDSF Mode Sample Display

### Display Erase and Autoblanking (Z86129 Only)

The display is erased in the TEXT mode by the Start Text command (but the box is maintained) and in the CAPTION mode by the Erase Displayed Memory (EDM) command. The non-displayed memory can be erased by the Erase Non-displayed Memory (ENM) command.

Four other events can also cause the display to be erased.

1. A change in the display mode, such as from CC1 to T1, CC1 to XDSF, and so forth, clears the memory and hence the display.
2. A loss of video lock, such as on a channel change, causes the screen to be cleared. The current active display mode does not change. For example if CC1 was selected and ON before the channel change the device remains in the CC1/ON state after channel change.
3. The third action that clears the displayed memory is the activation of the autoblanking circuit. The autoblanking circuit monitors the presence of a Line 21 waveform in the video field corresponding to the data channel selected for display. The decoder is held in the Decoder OFF (TV) state until a Line 21 waveform is continuously detected for a period of 0.5 seconds. When a valid Line 21 waveform has been detected for 0.5 seconds, and assuming that the user has selected the Decoder ON state, the normal display for the data

---

## Z86129/130/131 FUNCTIONAL DESCRIPTION (Continued)

channel selected is presented. The autoblanking circuit is not activate again until a valid Line 21 waveform has been lost for 1.5 seconds. Any data received during the 1.5-second period resets the counter so that autoblanking is only activated on continuous loss of the Line 21 waveform for 1.5 seconds.

---

**Note:** Valid Line 21 waveform is defined as the presence of a 7-cycle run-in clock and a start bit on Line 21 of the field being examined.

---

4. The fourth method of clearing the screen is by the action of the 16 Second Erase Timer. *This function is only active when a CAPTION or XDS display mode has been selected.* If no data is received for the display channel selected for a 16 second period, the on-screen memory is erased. The decoder is still in the selected channel and with the decoder ON, so that when data for the selected channels resumes, it is displayed.

## Z86129/130/131 FEATURE SET

As discussed, the Z86129/130/131 are defined differently for the requirements of Line 21 Data applications. However the part number, Z86129, is used to describe the feature set of the Z86129/130/131. In this description, there are some descriptions not applicable to the Z86130/131 for the feature differences listed on page 1.

The primary features of the Z86129 are briefly described below. More complete descriptions can be found in later sections of this document.

### VBI Data Processing

The Z86129 extracts the data in Line 21 of the incoming video. All data channels, in both video fields are supported. Specifically, the Z86129 can:

1. Process data from both fields of Line 21 simultaneously.
2. Output XDS data through the serial port while displaying selected data.
3. Output XDS data through the serial port raw or filtered.
4. XDS filters are selectable from a list of pre-programmed values including Program Rating and Time of Day/Local Time.
5. Output line 21 data through serial port raw (Z86130 only).
6. NTSC or PAL operation selectable.

The data extracted from Line 21 of the incoming video by the Z86129 may be displayed in different ways according to the user selection and the type of data. The display features available on the Z86129 only are:

1. Ten different Line 21 data display modes; CC1–CC4, T1–T4, plus two standard templates for XDS displays.
2. Pop-on, Paint-on and Roll-up CAPTION displays.
3. TEXT display default is a full screen, 15-row display.
4. User can vertically reduce and reposition the TEXT display as desired.
5. Color or Monochrome display mode selectable.
6. XDSG Display Mode (channel grazing): automatic display of Network Name, Call Letters, Program Name, Program Length, and Time In Show data packets.

7. XDSF Display Mode (full information): automatic display of XDSG Display Mode information plus: Program Type (only basic types), and Program Description.

### General Purpose OSD Modes (Z86129 Only)

In addition to displaying data extracted from Line 21 of the incoming video, the Z86129 can display information supplied through its serial port. This mode is referred to as On-Screen Display (OSD) display mode. This mode provides:

1. Programmable Full Screen OSD: 15 display rows by 32 character columns.
2. Graphics characters.
3. Double-High and Double-Wide characters.
4. Fully programmable display positioning; information may be placed anywhere on the screen.
5. Accepts externally supplied, or internally generated VSYNC to enable OSD even when no video is present.

### Character Set (Z86129 Only)

The Z86129 has a new character set with extended features, such as:

1. New font with descenders on lower case letters.
2. Optional display mode using drop shadow font (in other words, fringing appears on each character rather than a solid, “black box” background).
3. EIA–608 Extended Characters.
4. EIA–608 Background and Foreground attributes.
5. Special framing and graphics characters for OSD display.
6. Double-High and Double-Wide character display for OSD.
7. Fifteen scan lines per character row for OSD and TEXT.

---

**Note:** Contact the nearest ZiLOG Sales office for additional information on how to define your own custom OSD character set.

---

### Serial Communications Interface

Communications and control of the Z86129/130/131 is through a serial control interface. Two Serial Control

## Z86129/130/131 FEATURE SET (Continued)

Modes are available with the Z86129/130/131 performing as a slave device. These modes are:

1. A two wire, I<sup>2</sup>C interface.
2. A three wire, serial peripheral interface (SPI).
3. A total of five device pins are dedicated to the serial control port function. These pins are designated as:

**Table 11. Z86129/130/131 Serial Control Signals**

Signal	SMS	SCK	SDA	SDO	SEN
Pin #	6	15	14	16	4
I/O	I	I	I/O	O	I
I <sup>2</sup> C	0	CLK	Data	NA	1
SPI	1	CLK	Data In	Data Out	Enable

**Notes:**

SMS = Serial Mode Select High = SPI and Low = I<sup>2</sup>C.  
 SCK = Serial port clock for either Serial Mode.  
 SDA = Serial port data for I<sup>2</sup>C Mode and Data In for SPI Mode.  
 SDO = Serial Data Out for SPI Mode. Not used in I<sup>2</sup>C Mode.  
 SEN = SPI Mode Enable signal. Must be High for I<sup>2</sup>C Mode.

**I<sup>2</sup>C Mode.** The I2C port on the Z86129/130/131 always acts as a slave device. I2C Mode is selected by bringing the SMS pin Low and the SEN pin High. SEN must remain High whenever I2C mode is desired. If the SEN pin is brought Low, with SMS also Low, the part is reset. SDA and SCK are the data and clock lines of the I2C port, respectively. During I2C mode operation the VIN/INTRO signal (pin 13), can be configured to generate interrupt requests to the master device on selected events (see Note, next column).

**SPI Mode.** SSPI Mode is selected by making the SMS pin High. In SPI mode the Z86129/130/131 acts as a slave device. All communications are clocked in and out as 8-bit bytes. SCK is the serial clock (input), SDA is Data-In and SDO is Data-Out. The SEN pin enables communication when High. When Low, the SDO pin is tri-stated.

When SEN is brought High the part is synchronized and waiting for a Command. If SEN is tied High, the part can also be synchronized by a command string. During SPI mode operation the V<sub>IN</sub>/INTRO signal (pin 13), can be configured to generate interrupt requests to the master device on selected events (Z86129/131 only; see Note, next column).

---

**Caution:** When the SEN and SMS pins are made Low simultaneously, the part resets.

---

**Interrupt Generation.** The V<sub>IN</sub>/INTRO signal (pin 13) in Z86129/131 can be configured to provide an interrupt output on selected events. The configuration of V<sub>IN</sub>/INTRO (pin 13) is user programmable to be either of two states in Z86129/131:

1. An INPUT pin for acceptance of an external VSYNC timing signal(Z86129 only).
2. An OUTPUT pin for interrupt generation on a selected events(Z86129/131).

---

**Note:** Configuring V<sub>IN</sub>/INTRO as an output for interrupt generation is particularly useful when implementing the *V-Chip* feature with Z86129 in TVs and VCRs. In this configuration, Pin 13 is used to interrupt the host processor when the XDS Program Rating data packet is found. As a result the host processor is not burdened with monitoring or filtering the line 21 data stream. The Z86129/131 filters the Line 21 data stream for the host processor, and generates an interrupt only when the desired packet is found. V<sub>IN</sub>/INTRO pin becomes PB in Z86130 and it serves as Program Blocking output pin for *V-Chip* application.

---

## Setup and Operational Control

The Z86129/130/131 is extremely flexible and fully programmable through its serial communication port. The following tables provide a *partial list* of User-Programmable Features, User Selectable Display Modes, and Default Conditions upon Reset.

**Z86129/130/131 Programmable Features (OSD features are for the Z86129 Only)**

- Decoder ON/OFF
- TV scan lines per OSD row (13 or 15)
- EIA-608 extended attributes ON/OFF
- OSD drop shadow ON/OFF
- Color/Monochrome
- OSD Horizontal start position
- Text box size (# of rows)
- Text box starting row position
- NTSC or PAL

- Vertical Lock Source: Video or External  $V_{IN}$
- XDS Data Output, Raw or Filtered
- H Lock Source: Video or External HIN

In addition to the programmable features just listed, the Z86129 offers a choice of eleven display modes for user selection.

**Table 12. Z86129 Display Modes**

Display Mode	Display Data	NTSC Field	Language
CC1	L21 Closed Captions		
CC2	L21 Closed Captions	1 (odd)	I
CC3	L21 Closed Captions	1	II
CC4	L21 Closed Captions	2 (even)	I
T1	L21 TEXT	2	II
T2	L21 TEXT	1	I
T3	L21 TEXT	1	II
T4	L21 TEXT	2	I
XDSF	XDS	2	II
XDSG	XDS	2	N/A
OSD	User Defined Serial Port	via 2	N/A

The Z86129/130/131 is initialized on RESET to the following default conditions:

**Table 13. RESET Default Conditions**

Parameter	Reset Condition
Display Channel	CC1
Decoder	OFF
TEXT Size	15 rows
Lines/Row	13
Background	BOX
EIA-608 Extended Attributes	ON
Data Outputs	OFF
Video Standard	NTSC
Data Outputs	OFF
VCO Lock	Video
BOX Timing	13.5usec
Vertical Lock	Video
$V_{IN}$ /INTRO	INTRO & Disabled
Horizontal Lock	Video
Color/Mono	Color
OSD Display	Drop Shadow 15 lines/row

## SERIAL COMMUNICATIONS INTERFACE

Commands and data are sent to and from the Z86129/130/131 through its serial communications interface. Two Serial Control Modes are available. One mode is a two wire I<sup>2</sup>C bus interface. The other serial mode is a three wire, synchronous serial peripheral interface (SPI). In both cases the Z86129/130/131 acts as a slave device.

This port is the path for setting the configuration and operational modes of the device. It is also the port for outputting the recovered XDS data and for inputting the OSD data for display.

Five pins are dedicated to the control port function and one additional pin can be configured to provide an interrupt output. These pins are designated as indicated in Table 14.

**Table 14. Z86129/130/131 Serial Control Signals**

Signal	SMS	SCK	SDA	SDO	SEN
Pin #	6	15	14	16	4
I/O	I	I	I/O	O	I
I <sup>2</sup> C	0	CLK	Data	Hi-Z	1
SPI	1	CLK	Data In	Data Out	Enable

**Notes:**

SMS = Serial Mode Select High = SPI & Low = I<sup>2</sup>C.  
 SCK = Serial port clock for either Serial Mode.  
 SDA = Serial port data for I<sup>2</sup>C Mode and Data In for SPI Mode.  
 SDO = Serial Data Out for SPI Mode. Not used in I<sup>2</sup>C Mode.  
 SEN = SPI Mode Enable signal. Must be High for I<sup>2</sup>C Mode.

When the Vertical Lock = VIDEO, the V<sub>IN</sub>/INTRO (pin13) is configured as an output, providing the INTRO signal. This interrupt operation is available in either serial control mode.

The Z86129/130/131 is able to interrupt on the occurrence of any of several events. The master device clears the interrupt by writing to the Interrupt Request Register.

### I<sup>2</sup>C Bus Operation

The serial control mode in use is selected by the state of the SMS pin. When SMS is set Low, the Z86129/130/131 is in the I<sup>2</sup>C mode. In this mode, the Z86129/130/131 also supports a bidirectional two wire bus and data transmission protocol. The bus is controlled by the master device, which generates the serial clock (SCK), controls the bus access and generates the Start and Stop conditions. The SDA pin is the bidirectional Data line. In this mode, the SDO output is not used, and the pin is in its high-impedance state.

The Z86129/130/131 can receive or transmit data under control of the master device. The Z86129/130/131 is a slave

device. Communication is initiated when the master device sends the start condition followed by the Z86129/130/131 Slave Address Read byte (29h) or Slave Address Write byte (28h). The Z86129/130/131 responds with an Acknowledge. The I<sup>2</sup>C RD/nWR bit is the Least Significant Bit (LSB) of the I<sup>2</sup>C addresses listed Table 15.

**Table 15. Z86129/130/131 I<sup>2</sup>C Slave Addresses**

	READ	WRITE
I <sup>2</sup> C Address	29h	28h

**Note:** When the SMS and SEN pins are both Low, the part is in the RESET state. Therefore the SEN pin can be used to reset the part while in the I<sup>2</sup>C mode. The SEN pin may be tied to an NRESET signal or tied High if no reset is desired.

### The I<sup>2</sup>C Bus Protocol

1. Data transfer can only be started when the bus is not busy.
2. During data transfer, data transitions must not occur while the clock is High.

### Bus Conditions

Bus Conditions are defined as:

**Not Busy.** Data and Clock lines both High.

**Start.** A High-to-Low transition of SDA line while SCK line is High.

**Stop.** A Low-to-High transition of SDA line while SCK line is High.

**Acknowledge.** When addressed, the receiving device must output an acknowledge after the reception of each byte. The master device must generate the clock for the acknowledge bit. Acknowledge is SDA=Low. Not Acknowledge (NACK) is SDA=High.

**Data.** The data (SDA) is output by the transmitting device on the falling edge of SCK, MSB first. The receiving device reads the data, MSB first, on the rising edge of SCK.

Communication with the Z86129/130/131 is initiated when the master device sends the Z86129/130/131 slave address following a start condition. The Z86129/130/131 has a preset, single, seven-bit slave address. The Z86129/130/131 responds with an acknowledge. The eighth bit of the slave address is driven High for Read operations and Low for Write operations.



## Writing to the I<sup>2</sup>C Bus

All write commands are either one or two byte commands. The Z86129/130/131 is enabled when a Start condition followed by its Slave Address Write byte is received. It is disabled when it deems the command to have been completed or by a Stop condition. A new Start condition without a Stop condition begins a new sequence. Therefore, successive commands may be executed by successive strings of “Start—Slave Address—Command” sequences without any intervening Stop condition being sent.

**Note:** The number of data bytes to be received by the Z86129/130/131 is inherent in the command and the Z86129/130/131 responds with the acknowledge signal only for the number of bytes expected. If the master writes more bytes than expected, there is no acknowledge for the extra bytes.

A write to the Z86129/130/131 should always be preceded by executing a Status read to verify that the Z86129/130/131 is not busy. The Status register data is output immediately following the reception of the Slave Address Read. If the RDY bit is set, the master device can initiate its write sequence, always beginning with the Start condition. The first byte of a two byte command is always written first.

An example of the master’s sequence for writing a two-byte command (after RDY had been checked) would be:

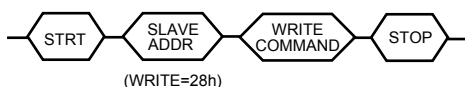
```

Start
Slave Address
Write/Slave ACK COMMAND (master)/Slave ACK
DATA (master)/Slave ACK
Stop
  
```

### I<sup>2</sup>C Two-Byte Write (Command & Data)



### I<sup>2</sup>C One-Byte Write (Command)



**Note:** Status Register RDY bit must be read and checked prior to the STRT condition of either WRITE sequence. See One Byte Read (Status Only) in Figure 13 for more information on reading the Status Register.

Figure 12. I<sup>2</sup>C Bus WRITE (Command)

## Reading Data Using the I<sup>2</sup>C Bus

With the exception of the Serial Status (SS) register, which may be read at any time, each read operation must be set up before the data can be read from the serial output registers of the Z86129/130/131. Data is set up for a read operation either automatically or manually. XDS data reads are set up automatically upon recovery by setting a valid XDS FILTER register selection. All other data read operations must be set up manually using the READ SELECT commands RDS1 and RDS2. These commands load the selected data byte or pair of bytes into the serial output register(s), set the SS register RD2 bit according to the number of data bytes requested and set the SS register DAV bit to indicate availability of data.

The Z86129/130/131 I<sup>2</sup>C Bus supports one, two and three byte read sequences. All read sequences output the SS register as the first output byte. If the serial status DAV bit is set, a two or three byte read sequence can then be initiated, beginning with a new STRT condition. If the DAV bit is not set, the I<sup>2</sup>C master device should not attempt to read any data bytes or the desired data can be lost from the Z86129/130/131 output registers.

The number of data bytes available is indicated by the state of the RD2 bit of the serial status. In a typical read operation the status byte is read and the DAV and RD2 bits are examined. If one or two data bytes are available they are read in sequence separated by acknowledges.

**Note:** In all I<sup>2</sup>C Read operations (one, two, and three byte as defined in Figure 13) the most recent byte read from the Z86129/130/131 should be acknowledged by the master with a NACK (Not ACKnowledge). It is also necessary to read all available data in a read operation to clear the DAV bit and permit subsequent reads. DAV is cleared by the master clocking out the eighth bit of the most recent data-byte read. DAV is never cleared by just reading the SSB (one-byte read) alone. All data is output MSB first.

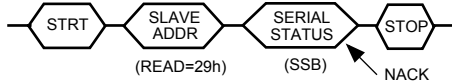
The master’s sequence for reading two *data bytes* (total of three bytes including SSB) from the Z86129/130/131 is as:

```

Start
Slave Address Read/Slave ACK
SS Byte/Master ACK
Byte (slave)/Master ACK
Byte (slave)/Master NACK
Stop
  
```

**SERIAL COMMUNICATIONS INTERFACE (Continued)**

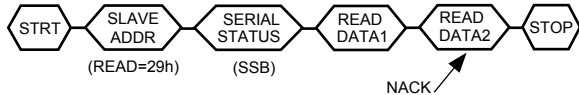
**I<sup>2</sup>C-One Byte Read (Status Only)**



**I<sup>2</sup>C-Two Byte Read (Status & Data1)**



**I<sup>2</sup>C-Three Byte Read (Status, Data1, & Data2)**



**Note:** In all I<sup>2</sup>C Read operations defined herein, the most recent byte read from the Z86129/130/131 must be acknowledged by the master with a NACK (Not ACKnowledge).

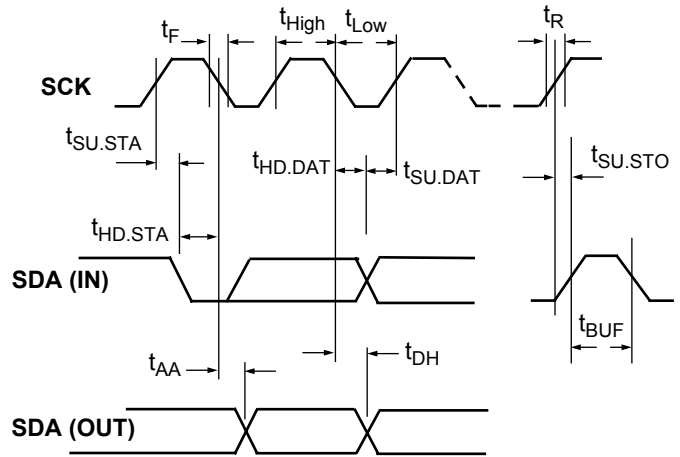
**Figure 13. I<sup>2</sup>C Bus READ (Command)**

**Clock and Data Transitions.** The SCK and SDA bus lines are normally pulled High with a resistor. Data on the SDA bus may only change during SCK Low time periods. Data changes during SCK High periods indicate a start or stop condition as defined in Table 16.

**Start Condition.** A High-to-Low transition of SDA with SCK High is a start condition which must precede any other command.

**Stop Condition.** A Low-to-High transition of SDA with SCK High is a stop condition which terminates all communications.

**Acknowledge.** All address and data words are serially transmitted to and from the Z86129/130/131 in eight-bit words. A ninth-bit time is used for the acknowledge. The device acknowledges by pulling the SDA bus Low during the ninth bit. A Not Acknowledge (NACK) is provided by SDA=High during the ninth clock time.



**Figure 14. I<sup>2</sup>C Serial Timing**

**Table 16. I<sup>2</sup>C Serial Timing**

Symbol	Parameter	Min	Max	Units
f <sub>SCK</sub>	Clock Frequency		100	kHz
t <sub>Low</sub>	Clock Pulse Width Low	4.7	–	μs
t <sub>High</sub>	Clock Pulse Width High	4.0	–	μs
t <sub>R</sub>	SDA and SCL Rise Time	–	1.0	μs
t <sub>F</sub>	SDA and SCL Fall Time	–	300	ns
t <sub>AA</sub>	Clock Low to Data Out Valid	0.1	3.5	μs
t <sub>BUF</sub>	Bus Free Time	4.7	–	μs
t <sub>HD.STA</sub>	Start Hold Time	4.0	–	μs
t <sub>SU.STA</sub>	Start Set-up Time	4.7	–	μs
t <sub>HD.DAT</sub>	Data In Hold Time	0	–	μs
t <sub>SU.DAT</sub>	Data In Set-up Time	250	–	ns
t <sub>SU.STO</sub>	Stop Set-up Time	4.7	–	μs
t <sub>DH</sub>	Data Out Hold Time	100	–	ns
t <sub>i</sub>	Input Filter Time Constant		100	ns

## SPI Bus Operation

When the SMS pin is High the Z86129/130/131 is in the SPI serial control mode. The clock line should be tied to the SCK pin. The DATA IN signal and DATA OUT signal from the master device should be connected to the SDA and SDO pins respectively. The SEN pin is used to select the Z86129/130/131 when there are multiple peripherals on the bus.

As noted above, when both the SMS and SEN pins are Low, the part is in the RESET state. When the SPI bus is used in a dedicated fashion between the master and the Z86129/130/131, both the SEN and SMS pins would be tied High. The RESET function would require that both of these pins be tied to the NRESET signal. To ensure synchronization, the master should send the serial synchronization signal after the reset is released.

When the SPI mode is used in a multiple peripheral environment, the SEN pin is used as the Z86129/130/131 enable signal. SMS could then be used for the NRESET signal as long as reset was only applied while SEN was Low. In this case, there would be no requirement for the master to send a serial synchronization string after reset if there was at least 100 ns between the end of reset and the start of port enable.

A command string can be interrupted at any time and the port resynchronized by sending the Serial Sync signal or by the rising edge of SEN.

The SPI bus is a three wire bus when used in a dedicated manner between the Z86129/130/131 and the master device. If other peripherals are connected to the bus, then the SEN pin must be used to place this device on the bus at the appropriate time. When SEN is Low, the SDO pin enters tri-state and transitions on the SCK and SDA pins are ignored.

If data output is not required from the Z86129/130/131, then control can be accomplished using only the SCK and SDA pins. Because this type of operation precludes the ability to check the RDY bit, it is very important that commands be spaced by at least two frames (66 msec) to ensure that one command has been executed before initiating another.

The bus is controlled by the master device, which generates the serial clock (SCK) and initiates all actions. Clocking data in on SDA simultaneously produces data out on SDO. The master should always check for the appropriate handshake signal before executing any command other than NOP.

Writing to the part requires that the RDY bit be set while reading from the part requires checking the SS register to see if the DAV bit is set. Both of these bits are contained

in the Serial Status (SS) register. Writing to the Z86129/130/131 concurrently outputs the contents of the SS register, MSB first, unless other data is being output as a result of one of the READ commands. If it is desired to read the SS without executing a command, the NOP command can be written at any time, even if the serial status RDY bit is not set.

The RDY status bit is driven onto the SDO pin between command transmissions. The controlling MCU can test the state of this pin without clocking in order to determine if subsequent serial transfers are possible. The DAV bit can only be checked by outputting the contents of the SS register.

## Writing to the SPI Bus

All write commands are either one or two byte commands. The number of data bytes to be received by the Z86129/130/131 is inherent in the command. If the master writes more bytes than expected, the command may be overwritten or corrupted by the extraneous bytes.

A write to the Z86129/130/131 should always be preceded by executing a Status read to verify that the device is ready. The serial status is output by the device concurrent with the input of any command byte. If the RDY bit of the serial status register is set, the master device can write a new command.

The command and data bytes are written MSB first. The first byte of a two byte command is sent first. The bits are clocked into the Z86129/130/131 by placing the data on the SDA input and bringing SCK High.

## Reading Data Using the SPI Bus

With the exception of the SS read, each read operation must be set up before the data can actually be read from the serial output registers of the device. Data is set up for a read operation either automatically or manually. XDS data is set up for READ automatically upon recovery by setting a valid XDS FILTER register selection. All other data read operations must be set up manually, using the READ SELECT commands RDS1 and RDS2. These commands load the selected data byte or pair of bytes into the serial output registers, set the SS register RD2 bit according to the number of data bytes requested and set the serial status DAV bit to indicate availability of data.

The Z86129/130/131 SPI Bus supports two and three byte read sequences. In SPI mode, the SS must be read before a read sequence is started so that the DAV and RD2 bits can be checked. The number of data bytes available is indicated by the state of the RD2 bit. The special command READ1 or READ2 is then used to read the one or two available data

## SERIAL COMMUNICATIONS INTERFACE (Continued)

bytes. The serial status is clocked out during the write of the READ1 or READ2 command. The data byte or bytes are then clocked-out in sequence, MSB first, while NOP commands are written into the device. Data bits are clocked-out on the rising edge of SCK. All available data bytes must be read to clear the DAV bit and permit subsequent reads.

### The SPI Bus Protocol

1. The first bit of the first output byte is driven out on SDO following the rising edge of SCK on the most recent bit (LSB) of the READ1 or READ2 command.
2. Three-wire bus with Clock signal on SCK pin, Serial Data Input on SDA pin and Serial Data Output on SDO pin.
3. SEN pin Low disabled the port, placing SDO in tri-state. Signal transitions on SCK and SDA are ignored.
4. SEN pin High enables the port for operation.
5. SEN and SMS pins Low is a hardware reset for the part. These pins must be held Low for at least 100 ns.
6. Serial synchronization can be established by clocking in the minimum required SSR string of FFh, FFh, FEh. More than two bytes of FFh may be input but the string must end with FEh.

## COMMANDS

### Serial Port Commands

The majority of the Z86129/130/131 commands are common to both the I<sup>2</sup>C and SPI modes. In the I<sup>2</sup>C mode, the commands must be contained within the Start—Slave Address sequence. Text or Caption display commands are available only in Z86129.

**Note:** In the following Command descriptions, the letter 'h' following a command code designates Hexadecimal notation.

### Reset

**RESET = FBh, FCh, 00h.** RESET is a three byte command sequence in SPI or I<sup>2</sup>C mode. The RESET command establishes all the specified default settings in the device, but it does not reset the serial port itself. This sequence can be entered without RDY being set.

### No Operation

**NOP = 00h.** NOP is a one-byte command for use in SPI or I<sup>2</sup>C mode. The NOP command does not affect the status of the RDY bit in the Serial Status (SS) register and can be executed independent of the RDY status.

### Serial Sync Bytes

**SSB = FFh,....,FFh,FEh.** Serial Sync Bytes are used in SPI mode only. This command actually consists of a string of single-byte commands in the form FFh,....FFh,FEh. SPI mode communications can be synchronized by sending a synchronizing data string to the part. This string should consist of at least two SSB bytes of FFh followed by one SSB byte of FEh. At the end of the FEh byte the port is ready for use.

Table 17. Basic Serial Commands

Serial Command	Command Code	Note
RESET	FBh, FCh, 00h	SPI or I <sup>2</sup> C
NOP	00h	SPI or I <sup>2</sup> C
SSB	FFh,...FFh,FEh	SPI mode only

### Caption/Text Display Mode Commands (Z86129 only)

**CPTX = 10h–1Fh.** Caption and Text display mode commands. These commands select the desired Line 21 data stream (Closed Caption or Text) for display.

Bit	CM7	CM6	CM5	CM4	CM3	CM2	CM1	CM0
	0	0	0	1	FLD	LANG	CPTX	DONOF
	R/W	R/W	R/W	R/W	R/W	R/W	R/W	R/W

Figure 15. CPTX—Caption/Text Display (CPTX = 10h–1Fh)

Caption and Text display commands are one byte commands. A data channel can be selected for display with the display either enabled (DEC ON) or disabled (DEC OFF). All these commands turn off an active XDS display mode. Table 18 summarizes the device's Caption and Text display modes and the proper command code to activate them:

Table 18. Caption and Display Commands

CPTX Command	CPTX Command Code	
	Decoder ON	Decoder OFF
CC1	17h	16h
CC2	15h	14h
CC3	1Fh	1Eh
CC4	1Dh	1Ch
T1	13h	12h
T2	11h	10h
T3	1Bh	1A
T4	19h	18

### XDS Display Mode and 16 Second Erase Timer Commands (Z86129 Only)

**XDS DISP = 20h–27h.** XDS Display commands are one byte commands. These commands control the selection of XDS display modes and the state of the 16 Second Erase Timer. The 16 Second Erase Timer is active only for Caption and XDS display modes. The 16 Second Erase Timer has no affect on TEXT mode displays.

**COMMANDS** (Continued)

**Table 19. XDS Display Commands**

XDS Display Command	XDS Display Command Code	
	16 Sec Tmr ON	16 Sec Tmr OFF
XDSG	23h	27h
XDSF	21h	25h
16 Second Erase Timer	20h	24h

**Note:** Changing the ON/OFF state of the 16 Second Erase Timer has no affect on the current display mode in operation.

**Read And Write Commands**

**Read Selects.** There are two Read Select commands (RDS1 and RDS2) in the Z86129/130/131. Each command is one byte in size and indicates that a read should take place. RDS1 specifies that one byte are read from the Z86129/130/131. Likewise, RDS2 indicates that two bytes are read.

**RDS1 = 40h–47h.** RDS1 is a one-byte command used to initiate a one-byte read sequence by moving the contents of the register identified by the address field (AD00:02) of the command to the output register. Addresses 0h–7h are valid in the RDS1 command field AD00:02.

Bit	CM7	CM6	CM5	CM4	CM3	CM2	CM1	CM0
	0	1	0	AD04	AD03	AD02	AD01	AD00
	W	W	W	W	W	W	W	W

**Figure 16. RDS1–Read One Byte (RDS1 = 40h–47h)**

**RDS2 = 60h–66h.** RDS2 is a one byte command which is used to initiate a two byte read sequence by moving the contents of the two consecutive registers, starting with the one identified by the address portion of the command (AD00:AD02), to the output registers and setting the RD2 bit in the SS register. Only Addresses 0h–6h are valid in the RDS2 command field AD00:02.

Bit	7	6	5	4	3	2	1	0
	0	1	1	AD04	AD03	AD02	AD01	AD00
	W	W	W	W	W	W	W	W

**Figure 17. RSD2–Read Two Bytes (RDS2 = 60h–66h)**

**Note:** For XDS data recovery, when the XDS Filter Register (see Internal Registers section, page 33) is enabled for the desired packets, the Z86129/130/131 automatically establishes the two-byte recovery mode and move the recovered data bytes to the output register.

**Reading Data From The Z86129/130/131**

**READ1 = F8h.** Command to read one byte in the SPI mode.

**READ2 = F9h.** Command to read two bytes in the SPI mode.

Bit	7	6	5	4	3	2	1	0
	1	1	1	1	1	0	0	RD2
	W	W	W	W	W	W	W	W

**Figure 18. READx–Read x Bytes (READ1/2 = F8h/F9h)**

The READx commands do not affect the status of the RDY bit in the Serial Status (SS) register and can be executed independent of the RDY status.

In both serial communications modes, the DAV bit in the SS register indicates when data is available. When the RD2 bit is Low, DAV is cleared on the rising edge of SCK at the LSB of the first data byte. When the RD2 bit is High, DAV is cleared on the rising edge of SCK at the LSB of the second data byte. The RD2 bit is only valid if DAV is High.

Reading in the I<sup>2</sup>C mode is selected by the R/NW bit in the Slave Address byte. The first byte after the Slave Address byte is SS followed by the data in output buffers A and B in that order. If the instruction being executed is a one- byte read, then buffer A contains the read data and buffer B contains all ones.

**Writing to the Z86129/130/131**

**WRxx = C0h–DFh**

Bit	7	6	5	4	3	2	1	0
	1	1	0	AD04	AD03	AD02	AD01	AD00
	W	W	W	W	W	W	W	W

**Figure 19. WRxx–Write Register xx (WRx = C0h–DFh)**

The WRITE commands require two bytes to execute. The first byte is the write command and includes the Z86129 register address (AD00:04) being written. The second byte is the data to be written.

#### OSD Display Mode Commands (Z86129 Only)

OSD commands are one and two byte commands. They are used to control the loading of data for OSD display and their

presentation to the screen. Normally OSD display mode uses 15 TV lines per display row to enhance the screen appearance. The following tables summarize the single- and two-byte control commands for the Z86129/130/131 On-Screen Display.

**Table 20. Single-Byte OSD Display Mode Commands (Z86129 Only)**

Command Name	Code	Command Function
RETURN	30h	Carriage return for OSD when in TEXTSET mode
CLRE	31h	OSD equivalent of delete to end of row (DER)
TEXTSET	32h	Establishes a TEXT type of OSD display
POPSET	33h	Establishes a pop-on type of OSD display
FLIP	36h	OSD equivalent of pop-on caption end of caption (EOC)
OEDM	37h	OSD equivalent of erase displayed memory
OENM	38h	OSD equivalent of erase non-displayed memory

**Table 21. Two-Byte OSD Display Mode Commands (Z86129 Only)**

Command Name	First Byte	Second Byte	Command Function
POP ROW SEL (with Double-High Option)	A0h	rrh	Sets display row and moves cursor to char column 1. The low order nibble of rr designates the display row. Bit 5 of rr specifies a Double-High row. For example: rr = 0Eh would select display row 14. rr = 23h would select display row three, Double-High.
PHYS ROW SEL	A1h	rrh	Sets the physical row, where the low order nibble of rr designates the physical row. rr can be any value from 00h to 0Fh.
CURSOR SET	A2h	cch	Places the cursor at the character column position designated by cc, which can be any value from 00h to 20h (column 0–32). Zero is the PAC space.
WRITE CHAR	A3h	ddh	Writes the data byte dd to the current cursor location and then increments the cursor.
WRITE MAP	A4h	rrh	Maps the current physical row to the display row designated by the low nibble of the rr byte. Bit 4 of rr = 1 enables display of the row. Bit 5 of rr = 1 indicates a Double-High row.
WRITE CHAR DBL WIDE	A5h	ddh	Same as A3 command but specifies a Double-Wide character.
WAIT	A6h	nnh	Sets the RDY bit of SS and then suspends serial command execution for approximately the number of frames designated by the nn byte.

Figure 20 illustrates the two different character sets, Graphics or Extended, that share the address space C0h–FFh. The Graphics Character set is in force when the OSD display is in Drop Shadow mode (the default condition).

The two-byte commands GRAPHICS and EXTENDED can be used to switch from the Graphics Characters to the Extended Characters and vice versa. An OSD screen can only use one set at a time.

COMMANDS (Continued)

	Ø	1	2	3	4	5	6	7	8	9	A	B	C	D	E	F
C	À	Á	Â	Ã	Ä	Å			É	Ê	Ë	Ï	Ñ			
D	Ì	Í	Î	Ï	Ò	Ó	Ô	Õ	Ù	Ú	Û	Ü	Ö			
E				ä	å	ä						ë				
F	ì			ï	ò			ó	ù			ü	ö			

	Ø	1	2	3	4	5	6	7	8	9	A	B	C	D	E	F
C																
D																
E																
F																

Figure 20. Z86129 Graphics or Extended Character Set



## INTERNAL REGISTERS

Information controlling the setup and operation of the Z86129/130/131 are maintained in several registers. The user may read or alter the contents of these registers as required. Some registers are not available in Z86130/131 for not supporting OSD or XDS filtering. The availability of the internal register depends on the function of the Z86129/130/131. This section describes all the internal register in the Z86129/130/131.

### Serial Status (SS) Register Address = Not Required

Bit	D <sub>7</sub>	D <sub>6</sub>	D <sub>5</sub>	D <sub>4</sub>	D <sub>3</sub>	D <sub>2</sub>	D <sub>1</sub>	D <sub>0</sub>
	RDY	DAV	RD2	WOVR	INTR	ROVR	FLD	LOCK
	R	R	R	R	R	R	R	R

**Figure 21. Serial Status Register (Address not required)**

**D<sub>0</sub>–LOCK.** Active High, indicating that the internal sync circuits are locked. May be used as an indication of the presence of a video signal.

**D<sub>1</sub>–FLD.** Signals the current video field. Low = Field 2, High = Field 1.

**D<sub>2</sub>–ROVR.** Active High, indicating that the data available in the output buffer has not been read out and new data has been written over it.

**D<sub>3</sub>–INTR.** Active High, indicating that an interrupt other than DAV is pending.

**D<sub>4</sub>–WOVR.** Active High, indicating a serial input data overrun.

**D<sub>5</sub>–RD2.** Signals the number of bytes available for output. Low = 1 byte, High = 2 bytes.

**D<sub>6</sub>–DAV.** Active High, indicating that data is available to be read out.

**D<sub>7</sub>–RDY.** Active High, indicating that the port input buffer is empty. Only the NOP, RESET and READ instructions may be sent if RDY is Low.

### Configuration Register Address = 00h

Bit	D <sub>7</sub>	D <sub>6</sub>	D <sub>5</sub>	D <sub>4</sub>	D <sub>3</sub>	D <sub>2</sub>	D <sub>1</sub>	D <sub>0</sub>
	res	res	res	res	VLK	HLK	MONO	TVS
					R/W	R/W	R/W	R/W

**Figure 22. Configuration Register (Address = 00h)**

**D<sub>0</sub>–TVS.** Selects the television standard. High selects PAL and Low selects NTSC. The default is NTSC. When PAL is selected the display defaults to 15 TV scan lines per display row.

**D<sub>1</sub>–MONO.** Selects monochrome operation. Active High, indicating that character luminance is output on all three color pins (RGB). The default is Low, selecting COLOR operation.

**D<sub>2</sub>–HLK.** Selects the horizontal signal source to be used to lock the VCO: Low = Internal, High = HIN. The default is Internal.

**D<sub>3</sub>–VLK.** Selects the vertical signal source to be used to establish vertical sync lock: Low = Internal, High = V<sub>IN</sub>. The default is Internal. When Internal lock is enabled the V<sub>IN</sub>/INTRO pin defaults to the INTRO output mode. Interrupts should not be selected in the Interrupt Mask register if VLK mode is used.

**D<sub>4</sub>–D<sub>7</sub>–res.** Reserved.

### Display Register Address = 01h

Bit	D <sub>7</sub>	D <sub>6</sub>	D <sub>5</sub>	D <sub>4</sub>	D <sub>3</sub>	D <sub>2</sub>	D <sub>1</sub>	D <sub>0</sub>
	O15	ODRP	CENH	C15	CDRP	TENH	T15	TDRP
	R/W	R/W	R/W	R/W	R/W	R/W	R/W	R/W

**Figure 23. Display Register (Address = 01h)**

**D<sub>0</sub>–TDRP.** Selects Drop Shadow or Full Box in TEXT mode: High = DROP SHADOW and Low = BOX. The default is Low.

**D<sub>1</sub>–T15.** Selects the number of TV lines per character row in a TEXT display: High = 15 lines/row and Low = 13 lines/row. The default is Low.

**D<sub>2</sub>–TENH.** Enables Enhanced Attributes for a TEXT display: High = Disabled, Low = Enabled. The default is Low.

**D<sub>3</sub>–CDRP.** Selects Drop Shadow or Full Box in CAPTION mode: High = DROP SHADOW and Low = BOX. The default is Low.

**D<sub>4</sub>–C15.** Selects the number of TV lines per character row in a CAPTION display: High = 15 lines/row and Low = 13 lines/row. The default is Low.

**D<sub>5</sub>–CENH.** Enables Enhanced Attributes for a CAPTION display: High = Disabled, Low = Enabled. The default is Low.

## INTERNAL REGISTERS (Continued)

**Note:** OSD and XDS display modes always have Enhanced Attributes enabled.

**D<sub>6</sub>—ODRP.** Selects Drop Shadow or Full Box in the OSD and XDS display modes: High = DROP SHADOW and Low = BOX. The default is High.

**D<sub>7</sub>—O15.** Selects the number of TV lines per character row in the OSD and XDS display modes: High = 15 lines/row and Low = 13 lines/row. The default is High.

### H Position Register Address = 02h

Bit	D <sub>7</sub>	D <sub>6</sub>	D <sub>5</sub>	D <sub>4</sub>	D <sub>3</sub>	D <sub>2</sub>	D <sub>1</sub>	D <sub>0</sub>
	BLUBX	HPO	h <sub>5</sub>	h <sub>4</sub>	h <sub>3</sub>	h <sub>2</sub>	h <sub>1</sub>	h <sub>0</sub>
	R/W	R/W	R/W	R/W	R/W	R/W	R/W	R/W

**Figure 24. H Position Register (Address = 02h)**

**D<sub>0</sub>—D<sub>5</sub>—h<sub>0</sub>—h<sub>5</sub>.** Used to set the Horizontal Timing of the display. The default value in this register is 26h. Each count change represents an incremental timing change of 330 ns. Decreasing the value of this field moves the display to the RIGHT. Conversely, increasing the value of this field moves the display to the LEFT.

**D<sub>6</sub>—HPO.** Set the polarity to be used for locking to the HIN signal when in the EXT HLK mode: Low = Rising Edge, High = Falling Edge. The default is Low.

**D<sub>7</sub>—BLUBX.** Designates color of BOX: High = Blue Box and Low = Black Box. The default is Low.

### Text Position Register Address = 03h

Bit	D <sub>7</sub>	D <sub>6</sub>	D <sub>5</sub>	D <sub>4</sub>	D <sub>3</sub>	D <sub>2</sub>	D <sub>1</sub>	D <sub>0</sub>
	y <sub>3</sub>	y <sub>2</sub>	y <sub>1</sub>	y <sub>0</sub>	x <sub>3</sub>	x <sub>2</sub>	x <sub>1</sub>	x <sub>0</sub>
	R/W	R/W	R/W	R/W	R/W	R/W	R/W	R/W

**Figure 25. Text Position Register (Address = 03h)**

**D<sub>0</sub>—D<sub>3</sub>—x<sub>0</sub>—x<sub>3</sub>.** Sets the Number Of Rows in the TEXT display. The default is 15 rows.

**D<sub>4</sub>—D<sub>7</sub>—y<sub>0</sub>—y<sub>3</sub>.** Sets the Base Row of the TEXT display.

The default value in this register is set to FFh, which produces a 15-row display with base row 15. Entering a new value in this register can alter the size and placement of the TEXT display. For example, to produce an 8 row TEXT display with a base row of 12, this register should be set to C8h.

If the value of the *x* and *y* bits result in a display where TEXT rows are off the top of the screen, then the first row of the TEXT display starts in row 1 and have the number of rows determined by the *x* value.

### Line 21 Activity Register Address = 04h

Bit	D <sub>7</sub>	D <sub>6</sub>	D <sub>5</sub>	D <sub>4</sub>	D <sub>3</sub>	D <sub>2</sub>	D <sub>1</sub>	D <sub>0</sub>
	res	res	res	res	res	res	XDS	SCH
							R	R

**Figure 26. Line 21 Activity Register (Address = 04h)**

**D<sub>0</sub>—SCH.** Indicates data being processed in the Data Channel selected for display, and becomes inactive if no data is received for the selected channel within the previous 16 seconds: High = Active, Low = Inactive. The reset state is Low.

**D<sub>1</sub>—XDS.** Indicates XDS data is being processed, and becomes inactive if no XDS data is received within the previous 16 seconds: High = Active, Low = Inactive. The reset state is Low.

**D<sub>2</sub>—D<sub>7</sub>—res.** Reserved.

### XDS Filter Register Address = 05h

Bit	D <sub>7</sub>	D <sub>6</sub>	D <sub>5</sub>	D <sub>4</sub>	D <sub>3</sub>	D <sub>2</sub>	D <sub>1</sub>	D <sub>0</sub>
	s <sub>2</sub>	s <sub>1</sub>	s <sub>0</sub>	PUBL	MISC	CHAN	FUTR	CURR
	R/W	R/W	R/W	R/W	R/W	R/W	R/W	R/W

**Figure 27. XDS Filter Register (Address = 05h)**

**D<sub>0</sub>—CURR.** Selects Current Class packets for output through the Serial Control port when XDS recovery has been enabled.

**D<sub>1</sub>—FUTR.** Selects Future Class packets for output through the Serial Control port when XDS recovery has been enabled.

**D<sub>2</sub>—CHAN.** Selects Channel Information Class packets for output through the Serial Control port when XDS recovery has been enabled.

**D<sub>3</sub>—MISC.** Selects Miscellaneous Class packets for output through the Serial Control port when XDS recovery has been enabled.

**D<sub>4</sub>—PUBL.** Selects Public Service Class packets for output through the Serial Control port when XDS recovery has been enabled.

**D<sub>5</sub>–D<sub>7</sub>–s<sub>0</sub>–s<sub>2</sub>.** Selects a set of secondary parameters (Table 22) to be used in filtering the XDS data when XDS recovery has been enabled.

**Table 22. XDS Secondary Filter Settings**

Secondary Filter	Filter Value (s0:s2)
All	0h
Time Information	1h
In Band Only	2h
Program Rating <sup>4</sup>	3h
VCR Information	4h
Reserved	5h
Reserved	6h
Reserved	7h

**Notes:**

- Setting this register to 00h turns XDS data recovery off. Setting bits D<sub>0</sub> through D<sub>4</sub> enables XDS data recovery for the Classes selected as qualified by the Secondary Filter (bits D<sub>5</sub>–D<sub>7</sub>). If Bits D<sub>0</sub>–D<sub>4</sub> are all set to 1, all Classes of XDS data are output (even Reserved and Undefined).
- The Time Information Only selection includes the Time of Day (TOD) and Local Time Zone (LTZ) packets.
- VCR Information selects TOD, LTZ, Net ID, Local Call Letters, Impulse Capture, Tape Delay, Composite 2 and Out of Band Channel Number packets for recovery.
- Program rating filter available on Z86129 only.

**Interrupt Request Register Address = 06h**

Bit	D <sub>7</sub>	D <sub>6</sub>	D <sub>5</sub>	D <sub>4</sub>	D <sub>3</sub>	D <sub>2</sub>	D <sub>1</sub>	D <sub>0</sub>
	dTXT	dCAP	dXDS	dSCH	dLOK	EOF	DLE	res
	R/W	R/W	R/W	R/W	R/W	R	R	R

**Figure 28. Interrupt Request Register (Address = 06h)**

**D<sub>0</sub>–res.** Reserved.

**D<sub>1</sub>–DLE.** Active High, indicating that the data line has ended. This bit clears in each field a few lines after row 15.

**D<sub>2</sub>–EOF.** Active High, indicating that the video signal is currently at the end of a field. This bit clears in each field a few lines after row 15.

**D<sub>3</sub>–dLOK.** Active High, indicating that the state of the LOCK signal has changed. The SS register must be read to determine the current state.

**D<sub>4</sub>–dSCH.** Active High, indicating that a change in selected channel activity has occurred. The Line 21 Activity register

must be read in order to determine if the selected data channel is active.

**D<sub>5</sub>–dXDS.** Active High, indicating that a change in XDS activity has occurred. The Line 21 Activity register must be read to determine if XDS data is active.

**D<sub>5</sub>–dXDS.** Active High, indicating that a change in XDS activity has occurred. The Line 21 Activity register must be read to determine if XDS data is active.

**D<sub>6</sub>–dCAP.** Active High, indicating that a change in a caption data channel activity has occurred. The Caption Activity Register (Address 08h) must be read to determine exactly which caption channels are now active.

**D<sub>7</sub>–dTXT.** Active High, indicating that a change in a TEXT data channel activity has occurred. The Caption Activity Register (Address 08h) must be read to determine exactly which TEXT channels are now active.

**Note:** Except as noted for the case of D<sub>1</sub> and D<sub>2</sub>, the master device must write a “1” to the appropriate bit in the Interrupt Request Register to clear the Interrupt. Writing a “1” to any valid bit position the Interrupt Request Register is equivalent to CLEARing a interrupt request on that bit.

**Interrupt Mask Register Address = 07h**

Bit	D <sub>7</sub>	D <sub>6</sub>	D <sub>5</sub>	D <sub>4</sub>	D <sub>3</sub>	D <sub>2</sub>	D <sub>1</sub>	D <sub>0</sub>
	dTXT	dCAP	dXDS	dSCH	dLOK	EOF	DLE	DAV
	R/W	R/W	R/W	R/W	R/W	R/W	R/W	R/W

**Figure 29. Interrupt Mask Register Address = 07h**

This register identifies which activities in the Interrupt Request Register are used to cause an interrupt. Setting a bit to a 1 enables the interrupt when the corresponding event becomes active. Setting all bits of this register to zero disables interrupts. Caption Activity Register Address = 08h.

**Caption Activity Register Address = 08h**

Bit	D <sub>7</sub>	D <sub>6</sub>	D <sub>5</sub>	D <sub>4</sub>	D <sub>3</sub>	D <sub>2</sub>	D <sub>1</sub>	D <sub>0</sub>
	T4	T3	T2	T1	CC4	CC3	CC2	CC1
	R	R	R	R	R	R	R	R

**Figure 30. Caption Activity Register (Address = 08h)**

**D<sub>0</sub>–D<sub>7</sub>–Activity Bits.** Activity bits for Line 21 data channels CC1–T4. Each bit is set High when a mode setting command for its data channel has been received on Line 21. The



**Note:** The Z86130 outputs Low when a bit in this register is set to Low and the incoming video program has the corresponding TV Parental Guidelines rating. Pin 13 may require a proper pull-down resistor for Low output. It outputs High onto pin 13 only when a bit is set High and it recovers the corresponding TV Parental Guidelines rating in the incoming video program. This control register is for the base rating of TV Parental Guidelines.

D<sub>3</sub> is read only. D<sub>7</sub>–D<sub>4</sub>, D<sub>2</sub>–D<sub>1</sub> are R/W.

Bit	D <sub>7</sub>	D <sub>6</sub>	D <sub>5</sub>	D <sub>4</sub>	D <sub>3</sub>	D <sub>2</sub>	D <sub>1</sub>	D <sub>0</sub>
-----	----------------	----------------	----------------	----------------	----------------	----------------	----------------	----------------

**Figure 33. TV Parental Guidelines Rating Blocking Control Register 2 (Address = 0Ah)**

**D<sub>0</sub>–TV–PG–S.** The Z86130 outputs High on pin 13 when incoming video program is “TV–PG–S” rated in TV Parental Guidelines Rating and this bit is set High.

**D<sub>1</sub>–TV–14–S.** The Z86130 outputs High on pin 13 when incoming video program is “TV–14–S” rated in TV Parental Guidelines Rating and this bit is set High.

**D<sub>2</sub>–TV–MA–S.** The Z86130 outputs High on pin 13 when incoming video program is “TV–MA–S” rated in TV Parental Guidelines Rating and this bit is set High.

**D<sub>3</sub>–res.** This bit must be kept Low, “0”.

**D<sub>4</sub>–TV–Y7–FV.** The Z86130 outputs High on pin 13 when incoming video program is “TV–Y7–FV” rated in TV Parental Guidelines Rating and this bit is set High.

**D<sub>5</sub>–TV–PG–V.** The Z86130 outputs High on pin 13 when incoming video program is “TV–PG–V” rated in TV Parental Guidelines Rating and this bit is set High.

**D<sub>6</sub>–TV–14–V.** The Z86130 outputs High on pin 13 when incoming video program is “TV–14–V” rated in TV Parental Guidelines Rating and this bit is set High.

**D<sub>7</sub>–TV–MA–V.** The Z86130 outputs High on pin 13 when incoming video program is “TV–MA–V” rated in TV Parental Guidelines Rating and this bit is set High.

**Note:** The Z86130 outputs Low when a bit in this register is set to Low and the incoming video program has the corresponding TV Parental Guidelines rating. Pin 13 may require a proper pull-down resistor for Low output. It outputs High onto pin 13 only when a bit is set High and it recovers the corresponding TV Parental Guidelines rating in the incoming video program. This control register is for the S and V rated programs in TV Parental Guidelines rating.

D<sub>7</sub>, D<sub>3</sub>–D<sub>2</sub> are read only. D<sub>6</sub>–D<sub>0</sub> are R/W.

Bit	D <sub>7</sub>	D <sub>6</sub>	D <sub>5</sub>	D <sub>4</sub>	D <sub>3</sub>	D <sub>2</sub>	D <sub>1</sub>	D <sub>0</sub>
-----	----------------	----------------	----------------	----------------	----------------	----------------	----------------	----------------

**Figure 34. TV Parental Guidelines Rating Blocking Control Register 3 (Address = 0Bh)**

**D<sub>0</sub>–TV–PG–D.** When it is High, Z86130 outputs High on pin 13 if incoming video program is “TV–PG–D” rated in TV Parental Guidelines Rating.

**D<sub>1</sub>–TV–14–D.** The Z86130 outputs High on pin 13 when incoming video program is “TV–14–D” rated in TV Parental Guidelines Rating and this bit is set High.

**D<sub>2</sub>–D<sub>3</sub>–res.** This bit must be kept Low (0).

**D<sub>4</sub>–TV–PG–L.** The Z86130 outputs High on pin 13 when incoming video program is “TV–PG–L” rated in TV Parental Guidelines Rating and this bit is set High.

**D<sub>5</sub>–TV–14–L.** The Z86130 outputs High on pin 13 when incoming video program is “TV–14–L” rated in TV Parental Guidelines Rating and this bit is set High.

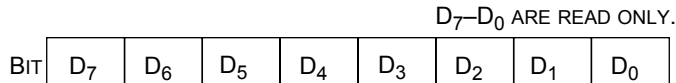
**D<sub>6</sub>–TV–MA–L.** The Z86130 outputs High on pin 13 when incoming video program is “TV–MA–L” rated in TV Parental Guidelines Rating and this bit is set High.

**D<sub>7</sub>–res.** This bit must be kept Low (0).

**Note:** The Z86130 outputs Low when a bit in this register is set to Low and the incoming video program has the corresponding TV Parental Guidelines rating. Pin 13 may require a proper pull-down resistor for Low output. It outputs High onto pin 13 only when a bit is set High and it recovers the corresponding TV Parental Guidelines rating in the incoming video program. This control register is for the D and L rated programs in TV Parental Guidelines rating.

## INTERNAL REGISTERS (Continued)

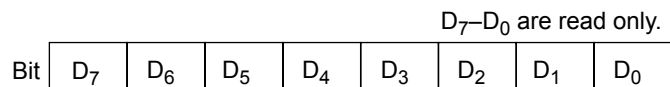
### Status Register Addresses = 0Ch–0Dh



**Figure 35. Status Register 1 (Address = 0Ch)**

**D<sub>0</sub>–D<sub>6</sub>.** These bits have the same format as the 7 LSb's(1, D, a1, a0, r2, r1, r0) of the first byte of 2 rating bytes received.

**D<sub>7</sub>–B.** This bit indicates the blocking status. When it is High, it indicates that the incoming video program falls into the set-up of program blocking.

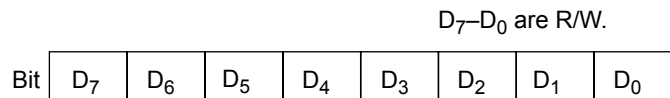


**Figure 36. Status Register 2 (Address = 0Dh)**

**D<sub>0</sub>–D<sub>6</sub>.** This bits have the same format as the 7 LSb's(1, (F)V, S, L, g2, g1, g0) of the second byte of 2 rating bytes received.

**D<sub>7</sub>–P.** This bit indicates the validity of the recovered ratings. When it is High, it indicates that the recovered rating of the incoming video program is valid.

### Blocking Control Register= 0Eh



**Figure 37. Blocking Control Register (Address = 0Ch)**

**D<sub>0</sub>–D<sub>6</sub>.** These bits extend the program blocking time as programmed when a channel change occurs on a program-blocking condition. These bits are optional control bits for the program-blocking vertical frame period of time will be incremented per the increment of 1 in this register.

**D<sub>7</sub>–Block.** This bit enables/disables the program blocking feature in Z86130.

### XDS Data Recovery

The Z86129/130/131 is able to recover Extended Data Services (XDS) information from the input video signal. This data, formatted according to EIA–608, can contain a wide variety of information about current and future programs,

the channel currently tuned, other channels and miscellaneous data including time of day.

XDS data is only present in the even field. The Z86129 can recover XDS data even while performing its normal caption decoder or OSD functions.

XDS data packets are tagged according to a Class/Type system defined by EIA–608. The Z86129/130/131(time information only for the Z86131) can be programmed to filter the XDS data stream to extract only the classes of interest to the application. An additional level of filtering is provided that permits selection of certain groups of packets that are of use in specific applications. XDS filtering reduces the traffic on the serial bus, reduces the load of the TV/VCR control processor and simplifies external XDS decoding.

XDS data recovery is enabled by selecting one or more classes in the XDS Filter register. Optionally, a secondary filter code can be specified which further limits the packets to be recovered. When XDS recovery is enabled filtered data pairs are loaded into the serial output registers of the Z86129/130/131 immediately upon receipt and in the order received. The DAV and RD2 bits of the Serial Status (SS) register then go High, indicating the availability of two output bytes. The external TV control processor is not required to send a READ SELECT command in order to read these data bytes.

When the XDS Filter register is set to 00h (the default state) XDS recovery is disabled.

---

**Caution:** When XDS data recovery is enabled, the external controller should never perform any other read operation, except SS reads, in the beginning of field 2. The user can most easily accomplish this task by using the end of field (EOF) or data line end (DLE) interrupt to locate the end of field 2 or the vertical blanking interval (VBI) of field 1, and then perform the READ SELECT and READ functions during this portion of the video frame. Commands other than READ SELECTS do not interfere with XDS data recovery regardless of their position in the video frame.

---

Some examples of Z86129/130/131 WRITE commands that could be used to set the XDS Filter Register are indicated in Table 23 (time information only for the Z86131). The XDS Filter Register bit assignments are defined in the Z86129/130/131 Internal Registers section, page 33 of this document.

**Table 23. XDS Data Extraction—  
Example Filter Settings**

{Write COMMAND, Filter Code}	XDS Filter Output
{C5,41}	All In Band, Current Class packets recovered.
{C5,61}	Program Rating, Current Class packets recovered. This Filter May be Used for V-Chip Data Packet Recovery.
{C5,1F}	All XDS packets recovered.
{C5,01}	All Current Class packets recovered.
{C5,28}	Time information recovered. This filter extracts the Time of Day (TOD) and Local Time Zone (LTZ) packets from the Miscellaneous Class data. This filter may be used to implement Auto Clock-Setting in TVs and VCRs.
{C5,9F}	VCR Information recovered. Selects TOD, LTZ, Net ID, Local Call Letters, Impulse Capture, Tape Delay, Composite 2 and Out of Band Channel Number packets for recovery.

### Filtered XDS Data Format

Filtered XDS data is output from the Z86129/130/131 in the order it is received on Line 21. In other words, think of the Z86129/130/131 XDS filter function as creating a new, smaller stream of XDS data packets. This new data stream looks exactly as though the Class and Type specified in the XDS Filter Register (05h) are *the only data* encoded on Line 21 of field 2. The filtered data output from the Z86129/131 is in full compliance with EIA-608 specifications for XDS data streams; headers and control codes intact. See Note paragraph in the next column for a special exception to this rule.

XDS data and header information (including START, CONTINUE, and END commands) are passed through the filter for the XDS class and type specified in the XDS Filter Register. All other Line 21 data is filtered out and is not output or used to generate a Data Available Flag (DAV) in the Serial Status Register.

To properly read filtered XDS data from the Z86129/130/131, the master device must first write the XDS Filter Register (05h) with its desired XDS Class and

Type information. For example, in Z86129/130, in order to extract ONLY the Line 21 Program Rating information, the master must write the value 61h to the XDS Filter Register. The master should then poll the state of the DAV bit in the SSR until DAV = 1.

As soon as DAV = 1, the master may initiate a 3-byte read in the normal manner (XDS data bytes always arrive in pairs, so it is safe to assume that RD2=1 when DAV=1 in the SSB). A 3-byte read always yields two data bytes, which in this case are the first two bytes of the Current Class, Program Rating Type XDS data stream encountered on Line21 field 2. The master device must then interpret those two bytes according to EIA-608 specifications for Current Class, Program Rating Type data. Refer to EIA-608 for data formats.

The XDS filters on the Z86129/130/131 greatly reduce the amount of field 2 data passed on to the master device for further processing and interpretation. However, the master device must still interpret the filtered data stream in accordance with EIA-608. The filtered data stream from the Z86129/131 is in full compliance with EIA-608. In other words, the filtered data stream contains all the XDS command and data packets, in standard EIA-608 format, but only for the selected XDS Class and Type(s).

**Note:** The Z86129/130 XDS filter for Program Rating information behaves differently than all other Z86129/130/131 predefined XDS filters. This change has been made to minimize the amount of data passed through the Program Rating XDS filter, thereby minimizing the interpretation and communications load on the master device. When the XDS Filter Register is set to 61h (Class=01h (Current), Type=05h (Program Rating)) the only data from Line 21 field 2 that passes through the filter is:

1. *Program Rating Packet: [xxh,xxh]*. The Current Class Program Rating data byte pair as defined in EIA-608. The program's rating is encoded per EIA-608 in the xxh byte pair.

2. *The END Packet [0Fh,CHKSUM]*. A two-byte packet that includes a CHKSUM computed per EIA-608. The checksum calculation includes the START packet [01h,05h] even though this value was not passed through the filter.

## Z86129/130/131 COMMANDS AND REGISTER SUMMARY (OSD AND CCD COMMANDS FOR Z86129 ONLY)

**Note:** As discussed, some registers are not available in Z86129/130/131 for non-OSD features in Z86130/131, V-chip-specific features in Z86130, and Time extraction feature only in Z86131.

**Table 24. Z86129/130/131 Summary of Control Commands**

Command Name	Command Code	Function
RESET	FBh, FCh, 00h	RESET is a three-byte command sequence in SPI or I <sup>2</sup> C mode. The RESET command establishes all the specified default settings in the device, but it does not reset the serial port itself. This sequence can be entered without RDY being set.
NOP	00h	NOP is a one-byte command for use in SPI or I <sup>2</sup> C mode. The NOP command does not affect the status of the RDY bit in the Serial Status (SS) register and can be executed independent of the RDY status.
SSB	FFh, ...Fh, FEh	Serial Sync Bytes are used in SPI mode only. This command actually consists of a string of single-byte commands in the form FFh, ..., FFh, FEh. SPI mode communications can be synchronized by sending a synchronizing data string to the part. This string should consist of at least two SSB bytes of FFh followed by one SSB byte of FEh. At the end of the FEh byte the port is ready for use.
CPTX	10h–1Fh	Selects a Closed Caption (CC1–CC4) or TEXT (T1–T4) data channel for processing or display.
DISP	20h–28h	Selects a preprogrammed XDS screen template for display, with or without 16 Second Erase timer enabled.
RDS1	40h–47h	RDS1 is a one-byte command used to initiate a one byte read sequence by moving the contents of the register identified by the address field (AD00:02) of the command to the output register. Addresses 0h–7h are valid in the RDS1 command field AD00:02.
RDS2	60h–66h	RDS2 is a one-byte command which is used to initiate a two-byte read sequence by moving the contents of the two consecutive registers, starting with the one identified by the address portion of the command (AD00:AD02), to the output registers and setting the RD2 bit in the SS register. Only Addresses 0h–6h are valid in the RDS2 command field AD00:02.
READ1	F8h	Command to read one byte in the SPI mode.
READ2	F9h	Command to read two bytes in the SPI mode.
WRxx	C0h–DFh, XXh	The WRITE commands require two bytes to execute. The first byte is the write command and includes the Z86129/130/131 register address (AD00:04) being written. The second byte (XXh) is the data to be written.



Table 25. Summary of Z86129/130/131 Internal Registers

Register Name	Address	D <sub>7</sub>	D <sub>6</sub>	D <sub>5</sub>	D <sub>4</sub>	D <sub>3</sub>	D <sub>2</sub>	D <sub>1</sub>	D <sub>0</sub>
Serial Status Register (SSR)	None	RDY	DAV	RD2	WOVR	INTR	ROVR	FLD	LOCK
Configuration	00h	res	res	res	res	VLK	HLK	MONO	TVS
Display <sup>1</sup>	01h	O15	ODRP	CENH	C15	CDRP	TENH	T15	TDRP
H Position <sup>1</sup>	02h	BLUBX	HPO	h <sub>5</sub>	h <sub>4</sub>	h <sub>3</sub>	h <sub>2</sub>	h <sub>1</sub>	h <sub>0</sub>
Text Position <sup>1</sup>	03h	y <sub>3</sub>	y <sub>2</sub>	y <sub>1</sub>	y <sub>0</sub>	x <sub>3</sub>	x <sub>2</sub>	x <sub>1</sub>	x <sub>0</sub>
Line 21 Activity <sup>1</sup>	04h	res	res	res	res	res	res	XDS	SCH
XDS Filter <sup>2</sup>	05h	s <sub>2</sub>	s <sub>1</sub>	s <sub>0</sub>	PUBL	MISC	CHAN	FUTR	CURR
Interrupt Request <sup>3</sup>	06h	dTXT	dCAP	dXDS	dSCH	dLOK	EOF	DLE	res
Interrupt Mask <sup>3</sup>	07h	dTXT	dCAP	dXDS	dSCH	dLOK	EOF	DLE	DAV
Caption Activity <sup>1</sup>	08h	T4	T3	T2	T1	CC4	CC3	CC2	CC1
MPAA Rating <sup>4</sup>	08h	res	Not Rated	X	NC-17	R	PG-13	PG	G
TV Parental Guidelines Rating <sup>14</sup>	09h	res	res	TV-MA	TV-14	TV-PG	TV-G	TV-Y7	TV-Y
TV Parental Guidelines Rating <sup>24</sup>	0Ah	TV-MA-V	TV-14-V	TV-PG-V	TV-Y7-FV	res	TV-MA-S	TV-14-S	TV-PG-S
TV Parental Guidelines Rating <sup>34</sup>	0Bh	res	TV-MA-L	TV-14-L	TV-PG-L	res	res	TV-14-D	TV-PG-D
Status <sup>14</sup>	0Ch	B	1	D	a1	a0	r2	r1	r0
Status <sup>24</sup>	0Dh	P	1	(F)V	S	L	g2	g1	g0
Block Control <sup>4</sup>	0Eh	Block				Block Time			

**Notes:**

1. These registers are not valid for the Z86130/131.
2. This register is valid in the Z86129/131. However, the Z86131 recovers time information only.
3. Bits D<sub>4</sub>, D<sub>5</sub>, D<sub>6</sub>, D<sub>7</sub> are not available in the Z86130/131; there is no Interrupt Output in the Z86130.
4. These registers are only available in the Z86130.

### APPLICATION INFORMATIONS OF THE Z86130 PROGRAM BLOCKING CONTROL

The following matrix is for the program blocking validity of the MPAA Rating in the Z86130. The first column is the control bits of the MPAA Blocking Control Register (Ad-

dress 08h) and the first row is the rating informations in the incoming video program.

	G	PG	PG-13	R	NC-17	X	NR
G							
PG							
PG-13							
R							
NC-17							
X							
NR							

The following matrix is for the program blocking validity of the TV Parental Guideline Rating in the Z86130. The first column is the control bits of the TV Parental Guideline

Blocking Control Registers (Address 09h, 0Ah, 0Bh) and the first row is the rating informations in the incoming video program.

	Y	Y7	G	PG												14												MA										
	-	-	F	-	V	S	L	D	V	V	V	S	L	V	V	V	S	S	L	V	V	V	S	V	-	V	S	L	V	V	S	V						
Y																																						
Y7																																						
Y7-FV																																						
G																																						
PG																																						
PG-V																																						
PG-S																																						
PG-L																																						
PG-D																																						
14																																						
14-V																																						
14-S																																						
14-L																																						
14-D																																						
MA																																						
MA-V																																						
MA-S																																						
MA-L																																						

**Note:** “-” denotes a base rating.

## ON-SCREEN DISPLAY (Z86129 Only)

### OSD Operation

The Z86129 has a fully programmable, general purpose OSD built in. The user can supply information for display through the serial port. In addition to all the normal and extended features of the VBI data display modes, OSD mode also has available added graphics characters, Double-High and Double-Wide characters and the ability to position the display anywhere on the screen with an adjustable (vertical) box size. The Double-High and double-wide characters are especially useful for creating OSD screens for display inside a Picture-in-Picture (PiP) window. The OSD display mode can use either 13 or 15 lines per row, with box or drop shadow. The default is 15 scan lines per row and drop shadow. Enhanced attributes are always enabled.

The 15 scan line per row display can only display 13 rows on-screen when in the NTSC mode. Rows 14 and 15 is off-screen and should not be addressed. In the PAL mode all rows are visible.

The 15 scan lines per row mode display can display the full graphic characters and accented capital letters and descenders without the potential overlap that would result from the 13 scan line per row display. If the OSD display mode is changed to a 13 scan line per row mode, the top two scan lines of any graphics or accented capital letter is "ORed" together with the bottom two scan lines from the row above. In 13 line-drop shadow mode, the result is a side-shadow effect. Graphics characters should not be used in the 13 line-drop shadow mode.

### OSD Character Set

There are 256 possible addresses in the OSD character set. Figure 38 illustrates the address map in the range 00h–BFh. This portion of the addressable space contains the control

bytes and regular character set. The address map in the range C0h–FFh is illustrated in Figure 20.

These addresses are shared by the Extended Character set and the Graphics Character set. Any particular OSD screen can use one or the other of these sets of characters but not both.

The character set in force is controlled by the type of display mode being invoked. When Drop Shadow is being used, by default, the Graphics Character set is displayed in response to an address in the C0h–FFh range. However, if a BOX display is used, the Extended Character set is invoked. In either case the user can switch to the other set by means of the appropriate command, GRAPHICS or EXTENDED.

The  $V_{IN}/INTRO$  pin serves as the input for a Vertical Pulse from the TV receiver when  $V Lock = V_{IN}$  mode is enabled. This mode permits an OSD display even when no video input is present. If this mode is not required, the default state  $V Lock = VIDEO$  should be active and this pin then carries the INTRO output signal.

### OSD Commands

OSD commands are one and two byte commands. They are used to control the loading of data for OSD display and their presentation to the screen. Normally OSD display mode uses 15 TV lines per display row to enhance the OSD presentation.

The two byte commands enable direct access to any location on the display screen. The user may construct displays of his own choosing by using these commands. Each command byte pair consists of an instruction byte followed by a data byte (see the Sample Z86129 OSD Program on page 45).

ON-SCREEN DISPLAY (Z86129 ONLY) (Continued)

Second Nibble	0	1	2	3	4	5	6	7	8	9	A	B	C	D	E	F	
First Nibble	0	White Char	White Underline Char	Green Char	Green Underline Char	Blue Char	Blue Underline Char	Cyan Char	Cyan Underline Char	Red Char	Red Underline Char	Yellow Char	Yellow Underline Char	Magenta Char	Magenta Underline Char	Italice Char	Italice Underline Char
1	®	°	½	¿	™	¢	£	♫	à	¡	è	â	ê	î	ô	û	
2	Opaque Space	!	"	#	\$	%	&	'	(	)	á	+	,	-	.	/	
3	0	1	2	3	4	5	6	7	8	9	:	;	<	=	>	?	
4	@	A	B	C	D	E	F	G	H	I	J	K	L	M	N	O	
5	P	Q	R	S	T	U	V	W	X	Y	Z	[	é	]	í	ó	
6	ú	a	b	c	d	e	f	g	h	i	j	k	l	m	n	o	
7	p	q	r	s	t	u	v	w	x	y	z	ç	÷	Ñ	ñ	■	
8	‘	’	©	SM	.	“	”	ß	¥	¤	ø	ç	”	°	«	»	
9	White Opaque Background	White Semitrans Background	Green Opaque Background	Green Semitrans Background	Blue Opaque Background	Blue Semitrans Background	Cyan Opaque Background	Cyan Semitrans Background	Red Opaque Background	Red Semitrans Background	Yellow Opaque Background	Yellow Semitrans Background	Magenta Opaque Background	Magenta Semitrans Background	Black Opaque Background	Black Semitrans Background	
A		—	—		—	—		—	—		—	—		—	—		
B	*	{	}	\	^	_		~	Transparent Space	Flash	Double Wide	Transparent Background	Transparent White Foreground	Transparent White Underline Foreground	Black Foreground	Black Underline Foreground	

Figure 38. OSD Character Set

**Note:** In this product specification, one and two byte commands are written as one or two, two-digit Hex values, separated by a comma, within curly braces. For example, the WRITE CHAR command for entering the letter “A” as a single-width character would be presented in this document as {A3,41}. This command would write the letter “A” to the current cursor position of the display row being addressed. Refer to the Serial Communications Interface and Commands sections, pages 24 and 29, respectively, for further details.

The one byte commands provide a simple means of creating OSD displays using preset screen formats built into the part. These built-in modes provide the user with a simple way to generate OSD screens. Two preset display modes are available called POPSET and TEXTSET.

### Using Popset

POPSET provides an OSD mode that operates in a fashion similar to the Caption Pop-on mode. The POPSET command organizes the memory into two eight row blocks, one visible on-screen and the other off-screen. An OSD screen can then be created by loading the off-screen memory by the command sequence POP ROW SEL, WRITE CHAR .. WRITE CHAR .. POP ROW SEL .. WRITE CHAR .. WRITE CHAR. The data can then be presented for on-screen display with the FLIP command.

The following is an example of a command sequence that creates an OSD screen using the POPSET mode. It creates a typical menu screen used in television receivers.

**Note:** In this document, commands are written as either a one- or two-byte HEX value, separated by a comma, within curly braces (for example, a two-byte OSD command is {A1,00}).

In the sample program that follows, a comment field is written following the command to describe the action of the command or sequence of commands, where appropriate.

The comment field is identified by an asterisk (\*); any text following the asterisk is implied as a “comment” in the examples that follow.

### Sample OSD Program

OSD Command	Function
{33}	*Select POP mode. Sets up the Z86129 internal memory organization to support POP mode. The first block of commands display > VIDEO in Double-Wide chars. Each character is entered with the WRITE CHARD command.
{A0,02}	*Select POPROW 2, cursor at character column1
{A2,00}	*move cursor to 0
{A3,08}	*PAC for RED chars written in PAC location.
{A5,3e}	*Double-Wide char “>” displays in char col 1 & 2
{A3,02}	*Green mid code written to char col 3
{A5,56}	*“V” written to char col 4 & 5.
{A5,49}	*“I”
{A5,44}	*“D”
{A5,45}	*“E”
{A5,4f}	*“O”
	*The next block of commands display AUDIO in row 4 double-width.
{A0,04}	*select poprow 4, cursor in char col 1
{A2,03}	*cursor to char col 3
{A3,02}	*Green mid code written to char col 3
{A5,41}	*“A” written to char col 4 & 5.
{A5,55}	*“U”
[A5,44]	*“D”
[A5,49]	*“I”

**Note:** \*The next set of commands display the word “TIME” in row 6 with double-wide characters. Spacing is obtained without the A2 Cursor Set command to illustrate an alternate means of column alignment.

**ON-SCREEN DISPLAY (Z86129 ONLY) (Continued)**

OSD	
Command	Function
{A0,06}	*Select poprow 6, cursor in char col 1
{A3,02}	*Green mid code written to character column 1
{A5,20}	*Double-Wide space char written to character columns 2 & 3
{A5,54}	*"T" written to char col 4 & 5.
{A5,49}	*"I"
{A5,4d}	*"M"
{A5,45}	*"E"

**Note:** \*SET UP is displayed in row 8 using double-wide chars.

OSD	
Command	Function
{A0,08}	*Select POPROW 8
{A2,03}	*cursor to 3
{A3,02}	*Green characters
{A5,53}	*"S"
{A5,45}	*"E"
{A5,54}	*"T"
{A5,20}	*" "
{A5,55}	*"U"
{A5,50}	*"P"

**Note:** \*CLOSED CAPTION displayed in row 10 using double-wide characters. The last letter, N, appears in character column 30 and 31

OSD	
Command	Function
{A0,0a}	*select poprow a
{A2,03}	*cursor to 3
{A3,02}	*Green char
{A5,43}	*"C"
{A5,4c}	*"L"
{A5,4f}	*"O"
{A5,53}	*"S"
{A5,45}	*"E"
{A5,44}	*"D"
{A5,20}	*" "
{A5,43}	*"C"
{A5,41}	*"A"
{A5,50}	*"P"
{A5,54}	*"T"
{A5,49}	*"I"
{A5,4f}	*"O"
{A5,4e}	*"N"

**Note:** \*The line, Select: ENTER EXIT: MENU, appears in row 12, starting in character column 2. These are displayed as single-wide characters

OSD	
Command	Function
{A0,0c}	*select poprow c
{A3,06}	*CYAN char
{A3,53}	*"S"
{A3,65}	*"e"
{A3,6c}	*"l"
{A3,65}	*"e"
{A3,63}	*"c"
{A3,74}	*"t"
{A3,3a}	*"."
{A3,20}	*" "
{A3,45}	*"E"
{A3,4e}	*"N"
{A3,54}	*"T"
{A3,45}	*"E"
{A3,52}	*"R"
{A3,20}	*" "
{A3,20}	*" "
{A3,45}	*"E"
{A3,78}	*"X"
{A3,69}	*"i"
{A3,74}	*"t"
{A3,3a}	*"."
{A3,20}	*" "
{A3,4d}	*"M"
{A3,45}	*"E"
{A3,4e}	*"N"
{A3,55}	*"U"
{36}	*FLIP command flips memories, and pops the full menu on-screen.

## Using Textset

TEXTSET features an OSD mode that paints on the screen in a manner similar to a TEXT Mode display. The memory is organized using the current information in the Text Position register and the display follows the current setting in the Display register. The default display parameters for OSD are 15 lines per row, Drop Shadow mode. The TEXTSET command can be followed by successive WRITE CHAR commands interspersed with the RETURN command at the appropriate points to paint on an OSD display starting at the top of the Text window as set by the Text Position register and moving to the next line at each RETURN command. The display scrolls if a RETURN command is sent when at the bottom of the Text window. A subsequent TEXTSET command clears the screen and generate a new OSD screen.

The following example presents an OSD display generated using TEXTSET. This screen paints on rather than pop on. Features like flash are included in the command sequence for demonstration purposes.

The TEXT display is first set to 4 rows at the bottom of the screen.

OSD	
Command	Function
{C3,D4}	*set Textpos reg for base row 13, 4 rows
{C1,80}	*set OSD display for BOX mode, 15 lines/row
{C2,A6}	*set BOX to Blue, keep HPOS unchanged
{32}	*select TEXTSET mode
	*The next two commands are used for positioning and color.
{A2,05}	*cursor to char pos 5
{A3,08}	*mid code to make Red chars. Cursor moves to 6
{A3,B9}	*mid code to start Flash, Cursor moves to 7
{A5,57}	*"W" Double-Wide, char col 7,8
{A5,41}	*"A" Double-Wide, char col 9,10
{A5,52}	*"R" Double-Wide, char col 11,12
{A5,4E}	*"N" Double-Wide, char col 13,14
{A5,49}	*"l" Double-Wide, char col 15,16
{A5,4E}	*"N" Double-Wide, char col 17,18
{A5,47}	*"G" Double-Wide, char col 19,20
{A5,20}	*" ' Double-Wide, char col 21,22
{30}	*Return moves cursor to next row, char pos 1
{A2,00}	*Cursor to char pos 0
{A3,0A}	*PAC sets color to Yellow, cursor moves to char pos 1
{A3,54}	*"T" single-width, cursor moves to char pos 2
{A3,68}	*"h"
{A3,65}	*"e"
{A3,72}	*"r"
{A3,65}	*"e"
{A3,20}	*" "
{A3,69}	*"i"
{A3,73}	*"s"
{A3,20}	*" "
{A3,61}	*"a"
{A3,20}	*" "
{A3,74}	*"t"
{A3,6F}	*"o"
{A3,72}	*"r"
{A3,6E}	*"n"
{A3,61}	*"a"

**ON-SCREEN DISPLAY (Z86129 ONLY) (Continued)**

OSD Command	Function
{A3,64}	*'d'
{A3,6F}	*'o'
{A3,20}	*' '
{A3,69}	*'i'
{A3,6E}	*'n'
{A3,20}	*' '
{A3,74}	*'t'
{A3,68}	*'h'
{A3,65}	*'e'
{A3,20}	*' '
{A3,61}	*'a'
{A3,72}	*'r'
{A3,65}	*'e'
{A3,61}	*'a'
{A3,2E}	*'.'
{30}	*Return moves cursor to next row, char pos 1
{A3,50}	*'P'
{A3,6C}	*'l'
{A3,65}	*'e'
{A3,61}	*'a'
{A3,73}	*'s'
{A3,65}	*'e'
{A3,20}	*' '
{A3,74}	*'t'
{A3,61}	*'a'
{A3,6B}	*'k'
{A3,65}	*'e'
{A3,20}	*' '
{A3,61}	*'a'
{A3,6C}	*'l'
{A3,6C}	*'l'
{A3,20}	*' '
{A3,6E}	*'n'
{A3,65}	*'e'
{A3,63}	*'c'
{A3,65}	*'e'
{A3,73}	*'s'
{A3,73}	*'s'
{A3,61}	*'a'
{A3,72}	*'r'
{A3,79}	*'y'
{30}	*
{A3,70}	*'p'
{A3,72}	*'r'
{A3,65}	*'e'

OSD Command	Function
{A3,63}	*'c'
{A3,61}	*'a'
{A3,75}	*'u'
{A3,74}	*'t'
{A3,69}	*'i'
{A3,6F}	*'o'
{A3,6E}	*'n'
{A3,73}	*'s'
{A3,20}	*' '
{A3,69}	*'i'
{A3,6D}	*'m'
{A3,6D}	*'m'
{A3,65}	*'e'
{A3,64}	*'d'
{A3,69}	*'i'
{A3,61}	*'a'
{A3,74}	*'t'
{A3,65}	*'e'
{A3,6C}	*'l'
{A3,79}	*'y'
{A3,2E}	*'.'

At this point, all 4 rows are on-screen. The following wait command holds the display for a period = (12x16)/30 seconds.

{a6,c0}	*wait for 6.4 seconds.
---------	------------------------

Create a smooth scroll to clear the screen with the following 4-row sequence.

OSD Command	Function
{30}	*Return, first row.
{a6,0f}	*wait 15 frames
{30}	*Return second row.
{a6,0f}	
{30}	*Return third row.
{a6,0f}	
{30}	*Return fourth row.
{a6,0f}	

Create a new screen display.





**ON-SCREEN DISPLAY (Z86129 ONLY) (Continued)**

OSD Command	Function
{A3,08}	*PAC, RED char
'The Z86129 has many features'	
{A0,04}	*select poprow 4
{A2,00}	*cursor to 0
{A3,04}	*Blue char
'besides displaying Captions.'	
{A0,06}	*select poprow 6
{A2,00}	*Move cursor to 0
{A3,07}	*PAC, Cyan Underlined
'Color and Underline may be used'	
{A0,08}	*select poprow 8
{A2,00}	*Move cursor to 0
{A3,0a}	*PAC, Yellow chars
**"Double-Wide"	
{A0,09}	*select poprow 9
{A2,00}	*Move cursor to 0
{A3,0c}	*PAC, Magenta chars
**"Graphics can be created like"	

The next group of commands use Graphic Char patterns to make the two-row word HELLO. The data byte of the WRITE CHAR command is the address location for the graphic cell desired as illustrated in Figure 9.

OSD Command	Function
{A0,0b}	*select poprow 11
{A2,00}	*Move cursor to 0
{A3,06}	*PAC, Cyan chars
{84,30}	*Set Graphics mode in case another user had changed it earlier.
{A5,20}	**"
{A5,20}	**"
{A5,20}	**"
{A5,20}	**"
{A3,20}	**"
{A3,eb}	*Graphic Cell
{A3,ea}	*Graphic Cell

OSD Command	Function
{A3,20}	**"
{A3,fb}	*Graphic Cell
{A3,20}	**"
{A3,ea}	*Graphic Cell
{A3,20}	**"
{A3,ea}	*Graphic Cell
{A3,20}	**"
{A3,fa}	*Graphic Cell
{A3,f5}	*Graphic Cell
{A0,0c}	*select poprow 12
{A2,00}	*Move cursor to 0
{A3,06}	*PAC, Cyan chars
{A5,20}	**"
{A5,20}	**"
{A5,20}	**"
{A5,20}	**"
{A3,20}	**"
{A3,ea}	*Graphic Cell
{A3,ea}	*Graphic Cell
{A3,20}	**"
{A3,eb}	*Graphic Cell
{A3,20}	**"
{A3,eb}	*Graphic Cell
{A3,20}	**"
{A3,eb}	*Graphic Cell
{A3,20}	**"
{A3,eb}	*Graphic Cell
{A3,d7}	*Graphic Cell
*	
{36}	*flip
*	
*	

**Manual Row Mapping and Control**

For most OSD displays the POPSET, POP ROW SEL, FLIP, TEXTSET and RETURN commands should be used to control row positioning.

TEXTSET mode provides automatic row allocation from top to bottom of the screen with all rows continuously visible. Additionally, TEXTSET screens have a definable vertical window size and position and support automatic text scrolling at the bottom of the window.

POPSET screens are created in off-screen memory while the previous screen is displaying. Up to 8 rows of characters can be defined. These rows can be mapped to any of 15 display rows using the POP ROW SEL command. Double-High rows may also be defined with POP ROW SEL. The FLIP command is then used to “pop-on” up to 8 rows of characters replacing the previous screen. The off-screen rows may be mapped to the same row numbers as the on-screen rows.

In some applications it may be necessary to access the display hardware at a lower level to achieve special screen effects. Examples of these special situations include the following:

1. More than 8 on-screen rows required in a “pop-on” style screen.
2. Characters must be added dynamically to an on-screen display.
3. On-screen rows must be dynamically moved, disabled or enabled.

The Z86129 supports manual screen mapping and display control commands to handle these special applications. These commands allow each of the 16 physical rows of character memory implemented in the device to be mapped to any of 15 display row positions.

Additionally the 16 physical rows can be set for single or double height and independently enabled and disabled. Manual row mapping and control commands should only be used in the POPSET OSD mode.

The procedure for manual row control is as follows:

1. Use the POPSET command to select the OSD pop-up mode. This command prepares the Z86129 for OSD input, clears the row maps and erases character memory.
2. Select a physical row (0 through 15) using the PHY ROW SEL command.
3. Use the WRITE MAP command to set the display row (1 through 15), Double-High bit, and enable bit of the selected physical row.

The CURSOR SET, WRITE CHAR and WRITE CHARD commands are used to position the cursor and write the characters in the selected physical row.

A physical row may be re-selected at any time to change its characters, row maps, Double-High mode or enable status. For example, it may be desirable to load several rows of characters into physical memory without enabling them.

All of the rows could then be made to “pop” onto the screen immediately by setting their enable bits.

The following example uses manual row mapping and control to write three rows of characters. The first row is a Double-High row that is enabled before the characters are sent, thereby allowing the characters to “paint” onto the screen as they are received. The second and third row are not initially mapped or enabled when the characters are written. They are then mapped and enabled after a two second pause. A new row is then created off-screen to replace the third row. Finally, after a 2 second pause the second row is moved to a new display row, the original third row is disabled and the new third row is mapped and enabled.

**OSD**

**Command Function**

{33}	*select POPSET mode
{A1,00}	*select physical row 0
{A4,31}	*map it to display row 1, enable, double
{A2,02}	*cursor to 1
{A3,02}	*green
	*Double-Wide text
	*“The First Row”
{A1,01}	*select physical row 1
{A2,00}	*cursor to 0
{A3,0a}	*yellow
	*single wide text
	“These two rows are’
{A1,07}	*select prow 7
{A2,00}	*cursor to 0
{A3,06}	*cyan
	*Single wide text
	“enabled after a pause’
{A6,40}	*wait 2 seconds
	*do the map and enable
{A1,01}	*select physical row 1
{A4,16}	
{A4,16}	*map it to display row 6, enable
{A1,07}	*select prow 7
{A4,17}	*map it to drow 7, enable
	*prepare a new row to replace row 7

---

**ON-SCREEN DISPLAY (Z86129 ONLY) (Continued)**

---

**OSD**

**Command    Function**

---

{A1,08}      \*select physical row 8

{A2,00}      \*cursor to 0

{A3,06}      \*cyan

              \*Single wide text

'moved after a pause'

---

{A6,40}      \*wait 2 seconds

---

              \*make the modified display

{A1,01}      \*select physical row 1

{A4,1A}      \*map it to display row 10, enable, double

{A1,07}      \*select row 7

{A4,00}      \*disable it

{A1,08}      \*select row 8

{A4,1B}      \*map it to row 11,enable, double

---

## DEMONSTRATION PROGRAMS

### Communicating with the Z86129/130/131

Communications with the Z86129/130/131 is accomplished using its serial communications interface. Through hardware setup, this interface can be configured into either of two serial protocols, I<sup>2</sup>C or SPI. The details of hardware setup have been provided in the Serial Communications Interface section, page 24, and are not covered here. It is assumed that the user is familiar with the serial protocol requirements.

**Note:** In the following descriptions <ENTER> means press the Enter key. An asterisk (\*) signifies that everything following the asterisk in that line is a comment.

### I<sup>2</sup>C Operation

The Z86129/130/131 is configurable as an I<sup>2</sup>C slave device. The PC communicates with the Z86129/130/131 through its parallel port. These programs are not intended as examples of how to program the application but are only provided as a means of illustrating the serial control process and the capability of the Z86129/130/131.

The three programs available are titled IICO, SCRIPTI and XDSCAP. These programs have been compiled and run satisfactorily with the Z86129/130/131 in a test board. Compiled versions are available on disk. Contact your local ZiLOG sales office for further information on these programs.

### IICO Program

This program sends one byte to the Z86129/130/131 without checking the status of the READY bit. The program returns the contents of the Serial Status (SS) Register after the command has been entered. When the program is active the screen displays:

IIC Command Byte >

The user may enter any valid one byte command such as FBh (Reset) or 00h (NOP) and then hit the ENTER key. The screen then displays the byte entered and the SS register contents as follows:

IIC Byte = 00

IIC Status = 83h

This example presents that the NOP command was entered. The SS register contents, 83h, indicates that the RDY, FLD and LOCK bits are High indicating that the serial port is ready for further input, that the input video signal was in

Field 1 at the time the status was read and that the part is operating in video lock mode.

The IICO program is exited by entering a Control+C (^C) character.

For example, entering the following single byte commands would:

Reset the part	FB, FC, 00
Set the part to CC1 display mode, decoder ON(Z86129 only).	17h
Change to the XDS Graze display mode, 16 Second Timer ON(Z86129 only).	23h
Return to the CC1 display mode, decoder ON(Z86129 only).	17h

The commands that control most of the display capability of the Z86129 are all one byte commands which can be entered using the IICO program. These commands are tabulated below for convenience.

### General Commands

Serial Command	Command Code
RESET	FBh, FCh, 00h
NOP	00h
SSB	FFh,...FFh,FEh

### Caption/Text Display Mode Commands (Z86129 only)

**CPTX = 10h–1Fh.** Caption and Text display mode commands. These commands select the desired Line 21 data stream (Closed Caption or Text) for display. See the Commands section, page 29, for a complete description of the CPTX Display Mode command.

Bit	CM7	CM6	CM5	CM4	CM3	CM2	CM1	CM0
	0	0	0	1	FLD	LANG	CPTX	DONOF
	R/W	R/W	R/W	R/W	R/W	R/W	R/W	R/W

**Figure 39. CPTX–Caption/Text Display (CPTX = 10h–1Fh)**

Caption and Text display commands are one byte commands. A data channel can be selected for display with the display either enabled (DEC ON) or disabled (DEC OFF). All these commands turn off an active XDS display mode. The following table summarizes the device’s Caption and

## DEMONSTRATION PROGRAMS (Continued)

Text display modes and the proper command code to activate them.

CPTX Command	CPTX Command Code	
	Decoder ON	Decoder OFF
CC1	17h	16h
CC2	15h	14h
CC3	1Fh	1Eh
CC4	1Dh	1Ch
T1	13h	12h
T2	11h	10h
T3	1Bh	1A
T4	19h	18

### XDS Display Mode and 16 Second Erase Timer Commands(Z86129 Only)

**XDS DISP = 20h–27h.** XDS Display commands are one byte commands. These commands control the selection of XDS display modes and the state of the 16 Second Erase Timer. The 16 Second Erase Timer is active only for Caption and XDS display modes. The 16 Second Erase Timer has no affect on TEXT mode displays.

XDS Display Command	XDS Display Command Code	
	16 Sec Tmr ON	16 Sec Tmr OFF
XDSG	23h	27h
XDSF	21h	25h
16 SECOND ERASE TIMER	20h	24h

**Note:** Changing the ON/OFF state of the 16 Second Erase Timer has no affect on the current display mode in operation.

### SCRIPTI Program

This program is designed to send any number of one or two byte commands to the Z86129/130/131. The list of commands to be executed are contained in Script files that have the extension .SER. Examples of such files are is presented in the following paragraphs. SCRIPTI can be used to control the display modes in the same manner as the IICO program except that the one byte command to be sent must be in a Script file. For example a file called CC1.SER (Z86129 only) would contain the one byte command:

```
{17}* send CC1, decoder ON
```

The program is invoked by typing:

```
SI File_name<ENTER>
```

**Note:** File\_name without the .SER extension.

The screen displays:

```
EEG CCD2 Serial Interface Script Player Version
x.xx

Slave Address is 28h

Script File Done
```

The responding slave address is reported to the screen. When all the commands in the file have been successfully sent to the Z86129/130/131, the PC returns to the system prompt.

The program checks the RDY status before sending each byte. If, during the entry of a command, the RDY bit is not found to be a “one” after an extended wait, the program reports the contents of the SS register and then continue checking for RDY.

### Script Files

Script files can be generated to perform all of the setup and control functions required to use the part in an application. The script files that follow are examples of such files used to setup the Z86129/130/131 for different operating conditions. Some of the files contain only a single command while others include several commands. The user should refer to the Commands and Internal Registers sections, pages 29 and 33, respectively, for details. Although the following examples are organized according to a particular register, some of the files contain information for several registers.

### Configuration Register Script Files (OSD-Related Configurations Are For Z86129 Only)

File Name	COMMAND {xxh,yyh}	Comments
FIGM	{c0,02}	*set config to mono
FIGVH	{c7,00}	*set INT Mask register clear
	{c0,0c}	*set config to ext VLK & HLK
	{83,12}	*bit set ext V pulse for pos
FIGN	{c2,1d}	*center h display
	{c0,00}	*set config back to default state
FIGPAL	{c2,26}	*return h display to center
	{c1,d2}	*change display register to C15 & T15

File Name	COMMAND {xxh,yyh}	Comments
	{c3,ff}	*change text pos register to base row 15, 15 rows
	{c0,01}	*set config register to TVS=1. Changes VBI line to L22 PAL.

#### Display Register Script Files (Z86129 Only)

File Name	COMMAND {xxh,yyh}	Comments
DN	{c1,c0}	*set display register to default conditions
DT1	{c1,c1}	*set display register to TEXT drop shadow
DT2	{c1,c2}	*set display register to TEXT 15 lines per row
DT3	{c1,c3}	*set display register to TEXT drop shadow, 15 lines
DT3A	{c1,c3}	*15 tv lines and drop text
	{c3,dd}	*13 rows of text, base row 13
DCE	{c1,e0}	*disable CAP Enhanced mode

#### H Position Register Script Files (Z86129 Only)

File Name	COMMAND {xxh,yyh}	Comments
HPOSC	{c2,26}	*center box
HPOSR	{c2,1d}	*move box right 2.97 $\mu$ s (from center)
HPOSL	{c2,29}	*move box left 0.99 $\mu$ s (from center)
HPOSCB	{c2,a6}	*center box & make Box Blue

#### Text Position Register Script Files (Z86129 Only)

File Name	COMMAND {xxh,yyh}	Comments
TPOS15	{c3,ff}	*text, base row 15, 15 rows
TPOS13	{c3,fd}	*text, base row 15, 13 rows
TPOS10	{c3,fa}	*text, base row 15, 10 rows
TPOS10A	{c3,ba}	*text, base row 11, 10 rows

#### XDSCAP Program

This program performs the application's task of XDS data recovery. XDS recovery must first have been enabled through the appropriate XDS Filter command. Examples of Script files for setting the XDS Filter Register are provided on page 55.

The program is invoked by typing:

```
xdscap<ENTER>
```

When the program is invoked, the PC screen displays:

```
EEG CCD2 XDS Data Recovery Test Program
Version x.xx
```

Slave Address is 28h

The responding slave address is reported to the screen.

When communication is acknowledged, the program displays all XDS data recovered from those packets that were enabled through the XDS Filter command. For example:

```
{01,03}Current Program{00}{0F,7F}...etc
```

The ASCII characters are presented as ASCII characters while the non-printing characters are displayed by their Hex value within curly braces. Byte pairs, such as Class,Type, are presented as pairs within the curly braces, separated by a comma, for example, {01,03}.

If no data is received within approximately 45 seconds, the program times out, reports "Data Not Available", and exits.

**Note:** The XDSCAP program can also be exited by entering a Control C (^C) character.

#### XDS Filter Register Script Files

File Name	COMMAND {xxh,yyh}	Comments
FILA	{c5,1F}	*set xds filter to all
FIL0	{c5,00}	*set xds filter to none. Turns off xds recovery
FILCA	{c5,01}	*set xds filter to all current class
FILC	{c5,41}	*set xds filter to current, in band class
FILFA	{c5,02}	*set xds filter to all future class
FILCH	{c5,04}	*set xds filter to channel class
FILM	{c5,08}	*set xds filter for misc. info
FILTIME	{c5,28}	*set xds filter time only
FILVCR	{c5,9e}	*set xds filter vcr info

#### Using Interrupts

Interrupts involve the use of the Line 21 Activity Register, the Interrupt Request Register and the Interrupt Mask Register. The Z86129/130/131 must be configured for VLK internal so that the  $V_{IN}/INTRO$  signal, Pin 13 is an output pro-

## DEMONSTRATION PROGRAMS (Continued)

viding the interrupt output signal. There is no INTRO output in the Z86130 for PB output.

The interrupt status can be polled through bit D<sub>3</sub> of the Serial Status (SS) Register if the interrupt signal cannot be used.

Interrupts are disabled when the Interrupt Mask Register has been set to all zeros. Conversely, interrupts are enabled by setting one or more of the active bits to a one. When enabled, the INTRO signal becomes a one when the enabled mask event(s) becomes active. If more than one event has been activated, the Interrupt Request Register must be queried to determine which event has occurred. The DLE and EOF interrupts are cleared at the end of the field in which they occurred.

### Interrupt Mask Register Script Files

File Name	COMMAND {xxh,yyh}	Comments
INTRD	{c7,02}	*set DLE active
INTRLK	{c7,08}	*set dLOK active
INTRX	{c7,20}	*set dXDS active
INTRC	{c7,12}	*set DLE & dC/T active

### SPI Operation

The serial port of the Z86129/130/131 may be configured to operate as an I<sup>2</sup>C or SPI interface. The Z86129/130/131 always acts as the slave device with the master generating the required clock and input data signals. Two C language programs available from ZiLOG enable a PC to perform as the I<sup>2</sup>C or SPI master device of an application. The PC communicates with the Z86129/130/131 through its parallel port. These programs are not intended as examples of how to program the application but are only provided as a means of illustrating the serial control process.

The two programs available, SEROUT and SCRIPT are the SPI equivalent to the I<sup>2</sup>C programs IICO and SCRIPTI, respectively.

### SEROUT Program

This program sends one byte to the Z86129/130/131 without checking the status of the READY bit. The program returns the contents of the Serial Status (SS) Register after the command has been entered. When the program is active the screen displays:

### SPI Command Byte

The user may enter any valid one byte command such as 00h (NOP) and then hit the ENTER key. The screen then

displays the byte entered and the SS register contents as follows:

SPI Byte = 00

SPI Return Val = 83h

This example shows that the NOP command was entered. The SS register contents, 83h, indicates that the RDY, FLD and LOCK bits are “ones” indicating that the serial port is ready for further input, that the input video signal was in Field 1 at the time the status was read and that the part is operating in video lock mode.

When this program is used, a modified version of the RESET can only be used. It is entered as two, one-byte commands; FBh and 00h.

The SEROUT program is exited by entering a Control C (^C) character.

### Script Program

This program is designed to send any number of one or two-byte commands to the Z86129/130/131. The list of commands to be executed are contained in Script files that have the extension .SER. The Script files used with the I<sup>2</sup>C version, SCRIPTI, can be used with this program.

The program is invoked by typing:

SI File\_name<ENTER>

---

**Note:** File\_name without the .SER extension.

---

The screen displays:

```
EEG CCD2 Serial Interface Script Player
Version x.xx
Script File Done
```

When all the commands in the file have been successfully sent to the Z86129/130/131, the PC returns to the system prompt.

The program checks the RDY status before sending each byte. If, during the entry of a command, the RDY bit is not found to be a “one”, the program reports the contents of the SS register and then continues checking for RDY.

### Programs only for the Z86130

The Z86130 is designed specifically for the V-Chip applications. Most of the demo programs can be run as described, but the Z86130 must have its own demo programs, including the demo programs described in the previous section for accessing the program-blocking specific registers in it. For

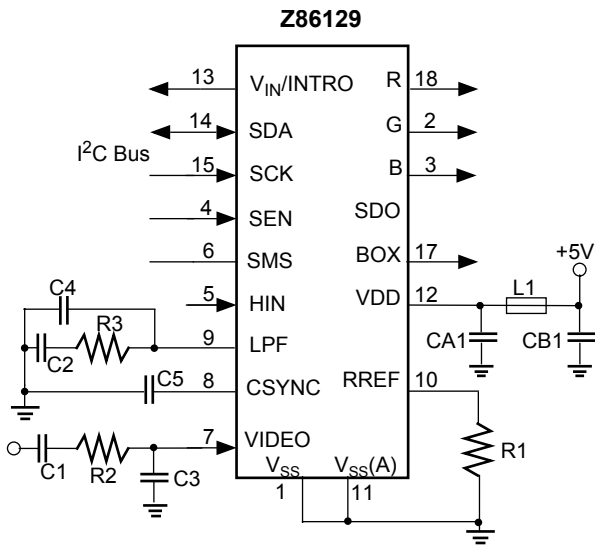
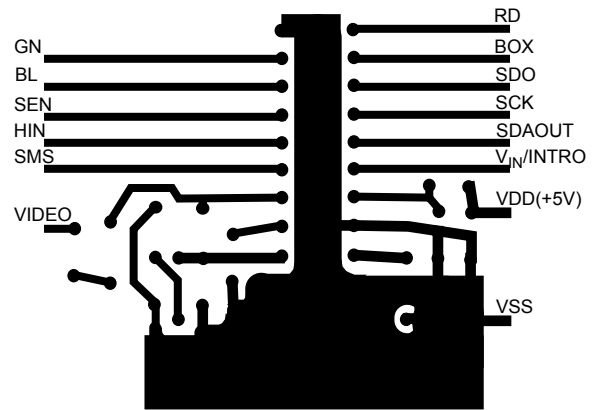


example, the registers from address 08h to 0Eh in the Z86130 are not available in the Z86129/131. There are 3 programs available for the Z86130:

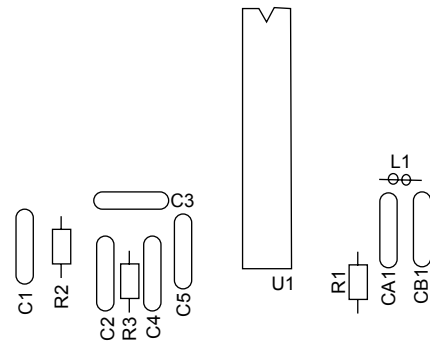
1. READ.EXE: Reads the content of the register from address 08h to 0Eh in the Z86130. It runs under DOS prompt and must type in the address to read after executing this program.
2. WRITE.EXE: Writes a byte data to the register from address 08h to 0Eh in the Z86130. It runs under DOS prompt and must type in the address to write the data after executing this program.
3. VCHIP.EXE: This program runs under Window95 and provides GUI environment to access the registers in the address from 08h to 0Eh. This demo program is specially developed to demonstrate how easy the V-Chip function can be implemented with the Z86130.

**APPLICATION INFORMATION**

The recommended schematic, component placement, and PCB layout for a single sided DIP design are provided in the following figures. EMI and noise in the video frequency range is kept to an absolute minimum by running the ground plane underneath the entire Z86129/130/131 package length. This design is recommended for both SOIC and DIP package styles. It is not presented in the following application information, but SMS (pin 6) must be grounded for I<sup>2</sup>C applications. Please contact ZiLOG, sales office in the event that there is any incompatibility or question in the following information:

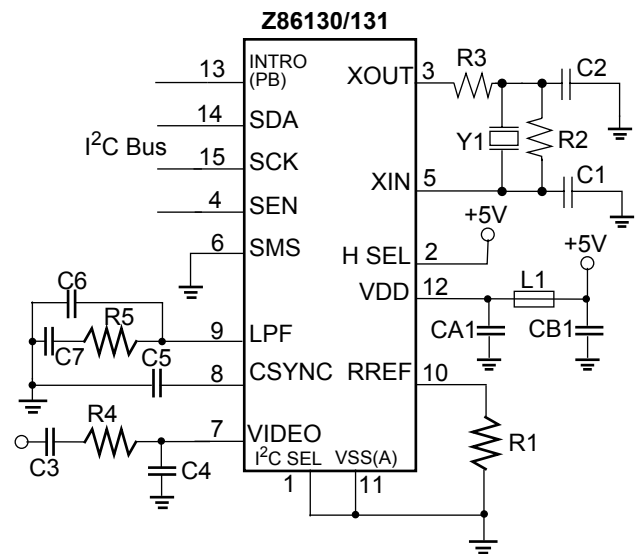


**Figure 40. Z86129 Application Circuit with I<sup>2</sup>C**



**Figure 41. Z86129 Application Circuit with I<sup>2</sup>C**

Component	Value	Units
R1	10	KW
R2	470	W
R3	6.8	KW
C1	0.1	μF
C2	0.068	μF
C3	560	pF
C4	6800	pF
C5	0.1	μF
CA1	0.1	μF
CB1	0.1	μF
L1	bead	TBD
U1	Z86129	N/A



**Figure 42. Z86130/131 Application Circuit with I<sup>2</sup>C**

Component	Value	Units
R1	10	K $\Omega$
R2	22	M $\Omega$
R3	470	K $\Omega$
R4	470	$\Omega$
R5	6.8	K $\Omega$
C1	10	pF
C2	20	pF
C3	0.1	$\mu$ F
C4	560	pF
C5	0.1	$\mu$ $\mu$ F
C6	6800	pF
C7	0.068	$\mu$ F
CA1	0.1	$\mu$ F
CB1	0.1	$\mu$ $\mu$ F
L1	bead	TBD
Y1	32.768	kHz
U1	Z86130/131	N/A

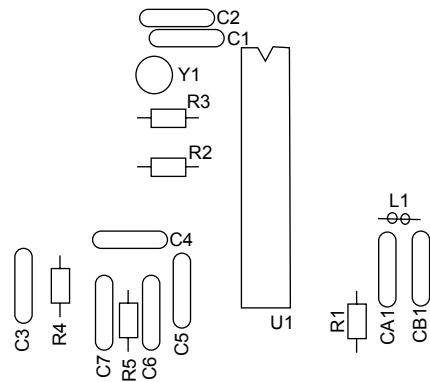
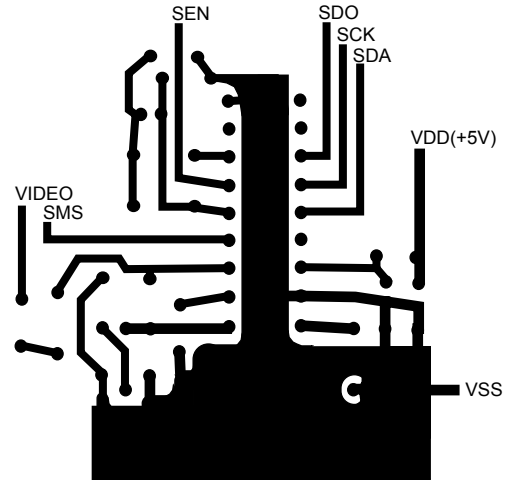
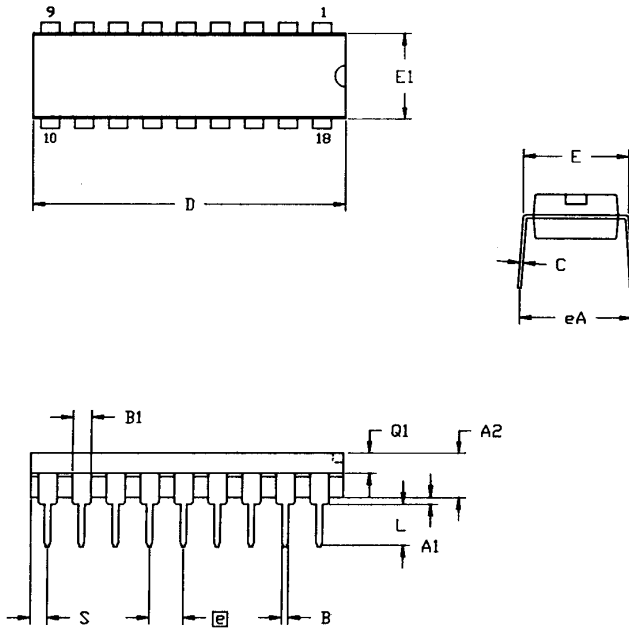


Figure 43. Z86130/131 Application Circuit with I<sup>2</sup>C

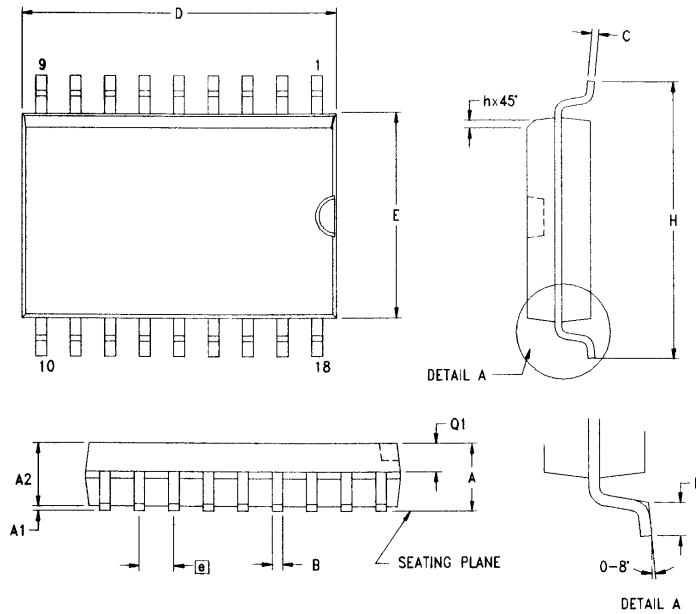
PACKAGING INFORMATION



SYMBOL	MILLIMETER		INCH	
	MIN	MAX	MIN	MAX
A1	0.51	0.81	.020	.032
A2	3.25	3.43	.128	.135
B	0.38	0.53	.015	.021
B1	1.14	1.65	.045	.065
C	0.23	0.38	.009	.015
D	22.35	23.37	.880	.920
E	7.62	8.13	.300	.320
E1	6.22	6.48	.245	.255
ⓐ	2.54 TYP		.100 TYP	
eA	7.87	8.89	.310	.350
L	3.18	3.81	.125	.150
Q1	1.52	1.65	.060	.065
S	0.89	1.65	.035	.065

CONTROLLING DIMENSIONS : INCH

Figure 44. 18-Lead DIP Package Diagram



SYMBOL	MILLIMETER		INCH	
	MIN	MAX	MIN	MAX
A	2.40	2.65	0.094	0.104
A1	0.10	0.30	0.004	0.012
A2	2.24	2.44	0.088	0.096
B	0.36	0.46	0.014	0.018
C	0.23	0.30	0.009	0.012
D	11.40	11.75	0.449	0.463
E	7.40	7.60	0.291	0.299
ⓐ	1.27 TYP		0.050 TYP	
H	10.00	10.65	0.394	0.419
h	0.30	0.50	0.012	0.020
L	0.60	1.00	0.024	0.039
Q1	0.97	1.07	0.038	0.042

CONTROLLING DIMENSIONS : MM  
LEADS ARE COPLANAR WITHIN .004 INCH.

Figure 45. 18-Lead SOIC Package Diagram

**ORDERING INFORMATION**

<b>Z86129/130/131 (12 MHz)</b>	
<b>18-Pin DIP</b>	Z8612912PSC
	Z8613012PSC
	Z8613112PSC
<b>18-Pin SOIC</b>	Z8612912SSC
	Z8613012SSC
	Z8613112SSC

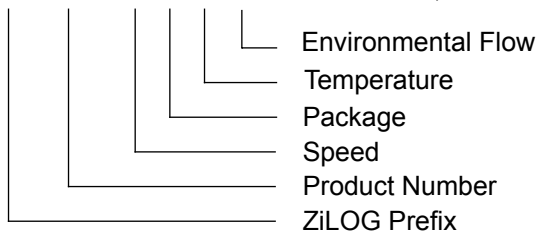
For fast results, contact your local ZiLOG sales office for assistance in ordering the part desired.

**CODES**

<b>Package</b>	P = Plastic DIP
	S = Plastic SOIC
<b>Temperature</b>	S = 0°C to + 70°C
<b>Speed</b>	12 = 12 MHz
<b>Environmental</b>	C = Plastic Standard

**Example:**

Z 86129 12 P S C is a Z86129, 12 MHz, DIP, 0°C to +70°C, Plastic Standard Flow



---

### Pre-Characterization Product

The product represented by this document is newly introduced and ZiLOG has not completed the full characterization of the product. The document states what ZiLOG knows about this product at this time, but additional features or nonconformance

with some aspects of the document may be found, either by ZiLOG or its customers in the course of further application and characterization work. In addition, ZiLOG cautions that delivery may be uncertain at times, due to start-up yield issues.

---

### Development Projects

Customer is cautioned that while reasonable efforts will be employed to meet performance objectives and milestone dates, development is subject to unanticipated problems and delays.

No production release is authorized or committed until the Customer and ZiLOG have agreed upon a Product Specification for this product.

---

©1999 by ZiLOG, Inc. All rights reserved. Information in this publication concerning the devices, applications, or technology described is intended to suggest possible uses and may be superseded. ZiLOG, INC. DOES NOT ASSUME LIABILITY FOR OR PROVIDE A REPRESENTATION OF ACCURACY OF THE INFORMATION, DEVICES, OR TECHNOLOGY DESCRIBED IN THIS DOCUMENT. ZiLOG ALSO DOES NOT ASSUME LIABILITY FOR INTELLECTUAL PROPERTY INFRINGEMENT RELATED IN ANY MANNER TO USE OF INFORMATION, DEVICES, OR TECHNOLOGY DESCRIBED HEREIN OR OTHERWISE.

Except with the express written approval of ZiLOG, use of information, devices, or technology as critical components of life support systems is not authorized. No licenses are conveyed, implicitly or otherwise, by this document under any intellectual property rights.

ZiLOG, Inc.  
910 East Hamilton Avenue, Suite 110  
Campbell, CA 95008  
Telephone (408) 558-8500  
FAX (408) 558-8300  
Internet: <http://www.zilog.com>